

# **Bonfiglioli** Vectron

---

## Agile

Application manual  
Functional Safety





## CONTENT

<b>1</b>	<b>General information about the documentation .....</b>	<b>5</b>
1.1	Instruction manuals.....	5
1.2	This document .....	5
1.3	Warranty and liability .....	6
1.4	Obligation .....	6
1.5	Copyright .....	6
1.6	Storage.....	6
<b>2</b>	<b>General safety instructions and information on use.....</b>	<b>7</b>
2.1	Terminology .....	7
2.2	Designated use .....	7
2.3	Misuse .....	7
2.4	Residual risks.....	8
2.5	Safety and warning signs on frequency inverter.....	8
2.6	Warning information and symbols used in the Operating Instructions .....	9
2.6.1	Hazard classes.....	9
2.6.2	Hazard symbols .....	9
2.6.3	Prohibition signs .....	9
2.6.4	Personal safety equipment .....	9
2.6.5	Recycling .....	9
2.6.6	Grounding symbol.....	9
2.6.7	ESD symbol.....	10
2.6.8	Information signs .....	10
2.6.9	Font style in documentation .....	10
2.7	Directives and guidelines to be adhered to by the operator .....	10
2.8	Operator's/operating staff's responsibilities.....	10
2.8.1	Selection and qualification of staff .....	10
2.8.2	General work safety .....	10
2.8.3	Ear protectors .....	11
2.9	Organizational measures .....	11
2.9.1	General .....	11
2.9.2	Use in combination with third-party products.....	11
2.9.3	Handling and installation .....	11
2.9.4	Electrical connections.....	11
2.9.5	Safe operation .....	12
2.9.6	Maintenance and service/troubleshooting .....	12
2.9.7	Final decommissioning .....	12
<b>3</b>	<b>Safety Instructions on Function "Safe Torque Off" (STO) .....</b>	<b>14</b>
3.1	Approved Devices .....	15
3.1.1	Connection 3x AC 400/480 V .....	15
3.1.2	Connection 1x AC 230 V / 3x AC 230 V .....	15
<b>4</b>	<b>Information of Risk Analysis and Risk Assessment .....</b>	<b>16</b>
<b>5</b>	<b>General Description of Safety Function .....</b>	<b>17</b>
5.1	Integrated Safety Function.....	17
5.2	Functional Safety .....	17
5.3	Classification the safety requirement.....	17
<b>6</b>	<b>Description of ACTIVE Cube Safety Function .....</b>	<b>18</b>

<b>6.1</b>	<b>Definitions of the AGL Safety functions</b> .....	<b>18</b>
<b>6.2</b>	<b>Specification of the Safety Function 1 (SF1): STO</b> .....	<b>18</b>
<b>6.3</b>	<b>Specification of the Safety Function 2 (SF2): SS1</b> .....	<b>19</b>
<b>6.4</b>	<b>Description of Safety Function</b> .....	<b>20</b>
<b>6.5</b>	<b>Two-Channel Monitoring</b> .....	<b>21</b>
<b>6.6</b>	<b>Diagnosis function and enforced dynamizing</b> .....	<b>23</b>
<b>7</b>	<b>Requirements to be met by installation</b> .....	<b>24</b>
<b>7.1</b>	<b>Instructions on installation of safety equipment</b> .....	<b>24</b>
<b>7.2</b>	<b>External Safety Control Equipment</b> .....	<b>24</b>
<b>7.3</b>	<b>External DC 24 V power supply</b> .....	<b>25</b>
7.3.1	External DC 24 V voltage supply for group stop .....	25
<b>7.4</b>	<b>DC 24 V power supply by AGL</b> .....	<b>25</b>
<b>8</b>	<b>Requirements to be met in operation</b> .....	<b>25</b>
<b>9</b>	<b>Requirements to be met by acceptance inspection</b> .....	<b>26</b>
<b>10</b>	<b>Application Examples</b> .....	<b>27</b>
<b>10.1</b>	<b>STO according to Stop Category 0</b> .....	<b>27</b>
10.1.1	STO Direct Stop.....	27
10.1.2	STO Direct Stop with error exclusion "short circuit" in the cabinet.....	28
10.1.3	STO Direct Stop with Feedback to PLC .....	29
10.1.4	STO Direct Stop w/ Feedback to PLC w/ error exclusion "short circuit" in cabinet...30	
<b>10.2</b>	<b>SS1 according to Stop Category 1</b> .....	<b>31</b>
10.2.1	SS1 Direct Stop .....	31
10.2.2	SS1 Direct Stop with error exclusion "short circuit" in the cabinet .....	32
10.2.3	SS1 Direct Stop with Feedback to PLC.....	33
10.2.4	SS1 Direct Stop w/ Feedback to PLC w/ error exclusion "short circuit" in cabinet ...34	
10.2.5	Internal DC 24 V Supply, SS1 .....	35
<b>10.3</b>	<b>Group Stop, SS 1</b> .....	<b>36</b>
<b>10.4</b>	<b>Checklist</b> .....	<b>37</b>
<b>11</b>	<b>Safety Function Test Report</b> .....	<b>39</b>
<b>11.1</b>	<b>Characteristical Data</b> .....	<b>39</b>
<b>12</b>	<b>STO status (diagnosis)</b> .....	<b>39</b>
<b>13</b>	<b>Change index</b> .....	<b>40</b>

# 1 General information about the documentation

The present documentation complements the operating instructions Agile (AGL). It contains additional safety information and requirements for the operation of Agile (AGL) in safety-oriented applications. Use in safety-oriented machines shall be permissible only after this documentation has been read carefully and understood. The applicable basic standards as well as application-specific and specific national standards shall also be complied with – the standards referred to in this manual shall also be complied with.

## 1.1 Instruction manuals

For better clarity, the documentation is structured according to the customer-specific requirements made on the frequency inverter.

### Quick start guide

The Quick Start Guide describes the basic steps required for mechanical and electrical installation of the frequency inverter. The guided commissioning supports you in the selection of necessary parameters and the configuration of the frequency inverter by the software.

### Operating instructions

The Operating Instructions describe and document all functions of the frequency inverter. The parameters required for adapting the frequency inverter to specific applications as well as the wide range of additional functions are described in detail.

### Application manual

The application manual supplements the documentation for purposeful installation and commissioning of the frequency inverter. Information on various subjects connected with the use of the frequency inverter is described specific to the application.

If you need a copy of the documentation or additional information, contact your local representative of BONFIGLIOLI.

The present documentation was prepared with great care and it was subjected to extensive and repeated reviews. For reasons of clarity, it was not possible to include all details of all types of the product in the documentation. Neither was it possible to consider all conceivable installation, operation or maintenance situations. If you require further information or if you meet with specific problems which are not dealt with in sufficient detail in the documentation, contact your local BONFIGLIOLI agent.

We would also like to point out that the contents of this documentation do not form part of any previous or existing agreement, assurance or legal relationship. Neither are they intended to supplement or replace such agreements, assurances or legal relationships. The manufacturer's obligations are exclusively specified in the relevant purchase contract. This contract also contains all and any warranty regulations which may apply to the relevant scope of supply. These contractual warranty provisions are neither extended nor limited by the specifications contained in this documentation.

The manufacturer reserves the right to correct or amend the specifications, product information and omissions in these operating instructions without notice. The manufacturer shall not be liable for any damage, injuries or costs which may be caused by the aforementioned reasons.

This documentation was written in German. Other language versions are translated.

## 1.2 This document

The present documentation complements the operating instructions AGL (Device series Agile). It contains additional safety information and requirements for the operation or Agile (AGL) in safety-oriented applications. Use in safety-oriented machines shall be permissible only after this documentation has been read carefully and understood.

The applicable basic standards as well as application-specific and specific national standards shall also be complied with – the standards referred to in this manual shall also be complied with.

For this reason, make sure you read the user manual carefully.

### IMPORTANT:

**Compliance with the documentation is required to ensure safe operation of the frequency inverter. Bonfiglioli Vectron GmbH shall not be held liable for any damage caused by any non-compliance with the documentation.**



In case any problems occur which are not covered by the documentation sufficiently, please contact the manufacturer.

---

### **1.3 Warranty and liability**

BONFIGLIOLI VECTRON GmbH would like to point out that the contents of this user manual do not form part of any previous or existing agreement, assurance or legal relationship. Neither are they intended to supplement or replace such agreements, assurances or legal relationships. Any obligations of the manufacturer shall solely be based on the relevant purchase agreement which also includes the complete and solely valid warranty stipulations. These contractual warranty provisions are neither extended nor limited by the specifications contained in this documentation.

The manufacturer reserves the right to correct or amend the specifications, product information and omissions in these operating instructions without notice. The manufacturer shall not be liable for any damage, injuries or costs which may be caused by the aforementioned reasons.

In addition to that, BONFIGLIOLI VECTRON GmbH excludes any warranty/liability claims for any personal and/or material damage if such damage is due to one or more of the following causes:

- inappropriate use of the frequency inverter,
- non-compliance with the instructions, warnings and prohibitions contained in the documentation,
- unauthorized modifications of the solar inverter,
- insufficient monitoring of parts of the machine/plant which are subject to wear,
- repair work at the machine/plant not carried out properly or in time,
- catastrophes by external impact and Force Majeure.

### **1.4 Obligation**

This user manual must be read before commissioning and complied with. Anybody entrusted with tasks in connection with the

- transport,
- assembly,
- installation of the frequency inverter and
- operation of the frequency inverter

must have read and understood the user manual and, in particular, the safety instructions in order to prevent personal and material losses.

### **1.5 Copyright**

In accordance with applicable law against unfair competition, this user manual is a certificate. Any copyrights relating to it shall remain with

BONFIGLIOLI VECTRON GmbH  
Europark Fichtenhain B6  
47807 Krefeld  
Germany

This user manual is intended for the operator of the frequency inverter. Any disclosure or copying of this document, exploitation and communication of its contents (as hardcopy or electronically) shall be forbidden, unless permitted expressly.

### **1.6 Storage**

The documentation form an integral part of the frequency inverter. It must be stored such that it is accessible to operating staff at all times. In case the frequency inverter is sold to other users, this user manual must also be handed over.

## 2 General safety instructions and information on use

This chapter contains general safety instructions for the Operator and the Operating Staff. At the beginning of certain main chapters, some safety instructions are included which apply to all work described in the relevant chapter. Special work-specific safety instructions are provided before each safety-relevant work step.

### 2.1 Terminology

According to the documentation, different activities must be performed by certain persons with certain qualifications.

The groups of persons with the required qualification are defined as follows:

#### **Operator**

This is the entrepreneur/company who/which operates the frequency inverter and uses it as per the specifications or has it operated by qualified and instructed staff.

#### **Operating staff**

The term Operating Staff covers persons instructed by the Operator of the frequency inverter and assigned the task of operating the frequency inverter.

#### **Skilled Personnel**

The term Skilled Personnel covers staff that are assigned special tasks by the Operator of the frequency inverter, e.g. installation, maintenance and service/repair and troubleshooting. Based on their qualification and/or know-how, Skilled Personnel must be capable of identifying defects and assessing functions.

#### **Qualified electrician**

The term Qualified Electrician covers qualified and trained staff who has special technical know-how and experience with electrical installations. In addition, Qualified Electricians must be familiar with the applicable standards and regulations, they must be able to assess the assigned tasks properly and identify and eliminate potential hazards.

#### **Instructed person**

The term Instructed Person covers staff who was instructed and trained about/in the assigned tasks and the potential hazards that might result from inappropriate behavior. In addition, instructed persons must have been instructed in the required protection provisions, protective measures, the applicable directives, accident prevention regulations as well as the operating conditions and verified their qualification.

#### **Expert**

The term Expert covers qualified and trained staff who has special technical know-how and experience relating to frequency inverter. Experts must be familiar with the applicable government work safety directives, accident prevention regulations, guidelines and generally accepted rules of technology in order to assess the operationally safe condition of the frequency inverter.

### 2.2 Designated use

The frequency inverter is designed according to the state of the art and recognized safety regulations.

The frequency inverters are electrical drive components intended for installation in industrial plants or machines. Commissioning and start of operation is not allowed until it has been verified that the machine meets the requirements of the EC Machinery Directive 2006/42/EC and DIN EN 60204-1.

The frequency inverters meet the requirements of the low voltage directive 2014/35/EU and DIN EN 61800-5-1. CE-labelling is based on these standards. Responsibility for compliance with the EMC Directive 2014/30/EU lies with the operator. Frequency inverters are only available at specialized dealers and are exclusively intended for commercial use as per EN 61000-3-2.

No capacitive loads may be connected to the frequency inverter.

The technical data, connection specifications and information on ambient conditions are indicated on the rating plate and in the documentation and must be complied with in any case.

### 2.3 Misuse

Any use other than that described in "Designated use" shall not be permissible and shall be considered as misuse.

For, example, the machine/plant must not be operated

- by uninstructed staff,
- while it is not in perfect condition,
- without protection enclosure (e.g. covers),
- without safety equipment or with safety equipment deactivated,
- when general requirements, such as operating conditions and technical data, are not met.

The manufacturer shall not be held liable for any damage resulting from such misuse. The sole risk shall be borne by the operator.

### **Explosion protection**

The frequency inverter is an IP 20 ingress protection rating device. For this reason, use of the device in explosive atmospheres is not permitted.

## **2.4 Residual risks**

Residual risks are special hazards involved in handling of the frequency inverter which cannot be eliminated despite the safety-compliant design of the device. Residual risks are not obviously identifiable and can be a potential source of injury or a health hazard.

Typical residual hazards include:

### **Electrical hazard**

- Danger of contact with energized components due to a defect, opened covers or enclosures or improper working on electrical equipment.
- Danger of contact with energized components in frequency inverter if no external disconnection device was installed by the operator.

During operation, all covers must be installed correctly, and all electrical cabinet doors must be closed to minimize electrical hazards.

When LEDs and other indicating elements on the frequency inverter go out, this does not necessarily mean that the device is deenergized. Before carrying out any Work at the device where contact with energized parts might be possible, it must be checked in any case, i.e. irrespective of the status of any indicating elements that may be installed, if the device is deenergized.

### **Charged capacitors in DC link**

Sizes 1 through 7 (up to 160 kW): The DC-link may have dangerous voltage levels even up to 3 minutes after shutdown.

Size 8 (as from 160 kW): The DC-link may have dangerous voltage levels even up to 10 minutes after shutdown.

### **Electrostatic charging**

Touching electronic components entails the risk of electrostatic discharges.

### **Thermal hazards**

Risk of accidents by hot machine/plant surfaces, e.g. heat sink, transformer, fuse or sine filter.

### **Danger of equipment falling down/over, e.g. during transport**

Center of gravity is not the middle of the electrical cabinet modules.

## **2.5 Safety and warning signs on frequency inverter**

Comply with all safety instructions and danger information provided on the frequency inverter.

Safety information and warnings on the frequency inverter must not be removed.



## 2.6 Warning information and symbols used in the Operating Instructions

### 2.6.1 Hazard classes

The following hazard identifications and symbols are used to mark particularly important information:



#### DANGER

Identification of immediate threat holding a **high** risk of death or serious injury if not avoided.



#### WARNING

Identification of immediate threat holding a **medium** risk of death or serious injury if not avoided.



#### CAUTION

Identification of immediate threat holding a **low** risk of minor or moderate physical injury if not avoided.

#### NOTICE

Identification of a threat holding a risk of material damage if not avoided.

### 2.6.2 Hazard symbols

Symbol	Meaning	Symbol	Meaning
	General hazard		Suspended load
	Electrical voltage		Hot surfaces
	Danger of crushing		

### 2.6.3 Prohibition signs

Symbol	Meaning
	No switching; it is forbidden to switch the machine/plant, assembly on

### 2.6.4 Personal safety equipment

Symbol	Meaning
	Wear body protection
	Wear ear protectors

### 2.6.5 Recycling

Symbol	Meaning
	Recycling, to avoid waste, collect all materials for reuse

### 2.6.6 Grounding symbol

Symbol	Meaning
	Ground connection

### 2.6.7 ESD symbol

Symbol	Meaning
	ESD: Electrostatic Sensitive Devices, i.e. components and assemblies sensitive to electrostatic energy

### 2.6.8 Information signs

Symbol	Meaning
	Tips and information making using the frequency inverter easier.

### 2.6.9 Font style in documentation

Example	Font style	Use
<b>1234</b>	bold	Representation of parameter numbers
<i>Parameter</i>	inclined, font: Times New Roman	Representation of parameter names
<b>P.1234</b>	bold	Representation of parameter numbers without name, e.g. in formulas
<b>Q.1234</b>	bold	Representation of source numbers

## 2.7 Directives and guidelines to be adhered to by the operator

The operator must follow the following directives and regulations:

- Ensure that the applicable workplace-related accident prevention regulations as well as other applicable national regulation are accessible to the staff.
- An authorized person must ensure, before using the frequency inverter, that the device is used in compliance with its designated use and that all safety requirements are met.
- Additionally, comply with the applicable laws, regulations and directives of the country in which the frequency inverter is used.
- For liquid cooled frequency inverters, comply with the cooling water guideline VGB-R 455 P.
- Any additional guidelines and directives that may be required additionally shall be defined by the operator of the machine/plant considering the operating environment.

#### Operator's general plant documentation

- In addition to the Operating Instructions, the operator should issue separate internal user manuals for the frequency inverter. The Operating Instructions of the frequency inverter must be included in the Operating Instructions of the whole plant.

## 2.8 Operator's/operating staff's responsibilities

### 2.8.1 Selection and qualification of staff

- Any work on the frequency inverter may only be carried out by skilled personnel. The staff must not be under the influence of any drugs. Note the minimum age required by law. Define the staff's responsibility pertaining to all work on the frequency inverter clearly.
- Work on the electrical components may only be performed by a qualified electrician according to the applicable rules of electrical engineering.
- The operating staff must be trained for the relevant work to be performed.

### 2.8.2 General work safety

- In addition to the Operating Instructions of the machine/plant, any applicable legal or other regulations relating to accident prevention and environmental protection must be complied with. The staff must be instructed accordingly.  
Such regulations and/or requirements may include, for example, handling of hazardous media and materials or provision/use of personal protective equipment.
- In addition to this Operating Instructions, issue any additional directives that may be required to meet specific operating requirements, including supervision and reporting requirements, e.g. directives relating to work organization, workflow and employed staff.
- Unless approved of expressly by the manufacturer, do not modify the frequency inverter in any way, including addition of attachments or retrofits.

- Only use the frequency inverter if the rated connection and setup values specified by the manufacturer are met.
- Provide appropriate tools as may be required for performing all work on the frequency inverter properly.

### **2.8.3 Ear protectors**

- The frequency inverter produces noise. Due to noise development, frequency inverters should only be installed in normally unstaffed areas.
- Noise emission in operation is < 85 dB(A) in the case of sizes 1 through 7.
- Noise emission in operation is approx. 86 dB(A) in the case of size 8. Ear protectors must be used when staying near the frequency inverter.

## **2.9 Organizational measures**

### **2.9.1 General**

- Train your staff in the handling and use of the frequency inverter and the machine/plant as well as the risks involved.
- Use of any individual parts or components of the frequency inverter in other parts of the operator's machine/plant is prohibited.
- Optional components for the frequency inverter must be used in accordance with their designated use and in compliance with the relevant documentation.

### **2.9.2 Use in combination with third-party products**

- Please note that Bonfiglioli Vectron GmbH will not accept any responsibility for compatibility with third-party products (e.g. motors, cables or filters).
- In order to enable optimum system compatibility Bonfiglioli Vectron GmbH offers components facilitating commissioning and providing optimum synchronization of the machine/plant parts in operation.
- If you use the frequency inverter in combination with third-party products, you do so at your own risk.

### **2.9.3 Handling and installation**

- Do not commission any damaged or destroyed components.
- Prevent any mechanical overloading of the frequency inverter. Do not bend any components and never change the isolation distances.
- Do not touch any electronic construction elements and contacts. The frequency inverter is equipped with components which are sensitive to electrostatic energy and can be damaged if handled improperly. Any use of damaged or destroyed components will endanger the machine/plant safety and shall be considered as non-compliance with the applicable standards.
- Only install the frequency inverter in a suitable operating environment. The frequency inverter is exclusively designed for installation in industrial environments.
- If seals are removed from the case, this can result in the warranty becoming null and void.

### **2.9.4 Electrical connections**

- The five safety rules must be complied with.
- Never touch live terminals. In sizes 1 through 7, the DC-link may have dangerous voltage levels up to 3 minutes after shutdown. In size 8, the DC-link may have dangerous voltage levels up to 10 minutes after shutdown.
- When performing any work on/with the frequency inverter, always comply with the applicable national and international regulations/laws on work on electrical equipment/plants of the country in which the frequency inverter is used.
- The cables connected to the frequency inverters may not be subjected to high-voltage insulation tests unless appropriate circuitry measures are taken before.
- Only connect the frequency inverter to suitable supply mains. The frequency inverter may be operated in TN, TT and IT grid types. Precautions must be taken for operation in IT grids, see Chapter 7 "Electrical installation". Operation in a corner-grounded TN grid shall not be permissible.

#### **The five safety rules**

When working on/in electrical plants, always follow the five safety rules:

- 1 Disconnect
- 2 Secure to prevent restarting
- 3 check for absence of voltage,

- 4 carry out earthing and short-circuiting
- 5 cover or shield neighboring live parts

### **2.9.5 Safe operation**

- During operation of the frequency inverter, always comply with the applicable national and international regulations/laws on work on electrical equipment/plants.
- Before commissioning and the start of the operation, make sure to fix all covers and check the terminals. Check the additional monitoring and protective devices according to the applicable national and international safety directives.
- During operation, all covers must be installed correctly, and all electrical cabinet doors must be closed. During operation, never open the machine/plant.
- No connection work shall be carried out while power supply is on.
- The machine/plant holds high voltage levels during operation, is equipped with rotating parts (fan) and has hot surfaces. Any unauthorized removal of covers, improper use, wrong installation or operation may result in serious injuries or material damage.
- Some components, e.g. the heat sink or braking resistor, may be hot even some time after the machine/plant was shut down. Don't touch any surfaces directly after shutdown. Wear safety gloves where necessary.
- The frequency inverter may hold dangerous voltage levels until the capacitor in the DC link is discharged. After shutdown, wait for at least 3 minutes (sizes 1 through 7) and at least 10 minutes (size 8) before starting any electrical or mechanical work on the frequency inverter. Even after this waiting time, make sure that the equipment is deenergized in accordance with the safety rules before starting the work.
- In order to avoid accidents or damage, only skilled personnel and electricians may carry out the work such as installation, commissioning or setup.
- In the case of a defect of terminals and/or cables, immediately disconnect the frequency inverter from mains supply.
- Persons not familiar with the operation of the frequency inverter and children must not have access to the device.
- Do not bypass nor decommission any protective devices.
- The frequency inverter may be connected to power supply every 60 s. This must be considered when operating a mains contactor in jog operation mode. For commissioning or after an emergency stop, a non-recurrent, direct restart is permissible.
- After a failure and restoration of the power supply, the motor may start unexpectedly if the Auto-Start function is activated.  
If staff are endangered, a restart of the motor must be prevented by means of external circuitry.
- Before commissioning and the start of the operation, make sure to fix all covers and check the terminals. Check the additional monitoring and protective devices according to EN 60204 and applicable the safety directives (e.g. Working Machines Act or Accident Prevention Directives).

### **2.9.6 Maintenance and service/troubleshooting**

- Visually inspect the frequency inverter when carrying out the required maintenance work and inspections at the machine/plant.
- Perform the maintenance work and inspections prescribed for the machine carefully, including the specifications on parts/equipment replacement.
- Work on the electrical components may only be performed by a qualified electrician according to the applicable rules of electrical engineering. Only use original spare parts.
- Unauthorized opening and improper interventions in the machine/plant can lead to personal injury or material damage. Any repair work may only be carried out by the manufacturer or persons approved/licensed by the manufacturer. Any repair work must be carried out by qualified electricians. Check protective equipment regularly.
- Before performing any maintenance work, the machine/plant must be disconnected from mains supply and secured against restarting. The five safety rules must be complied with.

### **2.9.7 Final decommissioning**

- Unless separate return or disposal agreements were made, recycle the disassembled frequency inverter components:
- Scrap metal materials
- Recycle plastic elements
- Sort and dispose of other component materials



Electric scrap, electronic components, lubricants and other utility materials must be treated as special waste and may only be disposed of by specialized companies.

---



In any case, comply with any applicable national disposal regulations as regards environmentally compatible disposal of the frequency inverter. For more details, contact the competent local authorities.

---

### 3 Safety Instructions on Function "Safe Torque Off" (STO)

The function „Safe Torque Off" (STO) is a functional safety feature, i.e. it protects staff from damage, provided that projecting, installation and operation are performed properly. This function does not disconnect the plant from power supply.

In order to disconnect the plant from power supply (e.g. for maintenance work), an "Emergency Stop" provision as per EN 60204 must be installed.



#### WARNING

##### Uncontrolled Starting

Improper installation of the safety circuitry may result in uncontrolled starting of the drive. This may cause death, serious injuries and significant material damage.

Safety functions may only be installed and commissioned by skilled personnel.

The STO function is not suitable for emergency stop as per EN 60204. An emergency stop can be realized by installing a mains contactor.

An emergency stop according to EN 60204 must be functioning in all operation modes of the frequency inverter. Resetting of an emergency stop must not result in uncontrolled starting of the drive.

The drive is started again when the function STO is no longer required. In order to comply with EN 60204, it must be ensured by taking external measures that the drive does not start without prior confirmation.

Without a mechanical brake, the drive will not stop immediately but coast to a standstill. If this may result in personal or material damage, additional safety measures must be taken.

- If persons may be endangered after disconnection of the motor power supply by STO, access to the hazard areas must be prevented until the drive has stopped.
- Check the safety function at regular intervals according to the results of your risk analysis. Bonfiglioli Vectron MDS GmbH recommends that the check be performed after one year, at the latest.

The STO function is fail-safe for one fault. However, on rare occasions, the occurrence of component defects may cause jerking of the motor shaft (max. 180°/pole pair, e. g. jerk by 90° with 4-pole motor, 180°/2).

- Check if this causes a dangerous movement of the machine.
- If the STO function is used, the special safety, installation and instructions on use instructions shall be complied with.



#### WARNING

##### Dangerous voltage!

The safety function "Safe Torque Off" may only be used if mechanical work is to be performed on the driven machines, not for work on live components.

After disconnection of an external DC 24 V power supply, the DC link of the frequency inverter is still connected to mains supply.

Even if power supply to the motor is disconnected, and the motor is coasting to a standstill or has already stopped, high voltages may still be present on the motor terminals.

Before working (e. g. maintenance) on live parts, the plant must always be disconnected from mains supply (main switch). This must be documented on the plant.

When the function "Safe Torque Off" is triggered, the motor is not isolated from the DC link of the frequency inverter. High voltage levels may be present at the motor.

- Do not touch live terminals.



The application manual "Safe Torque Off STO" must be complied with, particularly if the safety function described there is used.

### **3.1 Approved Devices**

The following device variants of the Agile device series are approved for applications with functional safety. Additional to the below mentioned Type codes, the name plate of these devices contains a "STO certified" logo.

#### **3.1.1 Connection 3x AC 400/480 V**

AGL402-XX1FY-XXXXXXXS

AGL402-XX2FY-XXXXXXXS

AGL402-XX3FY-XXXXXXXS

With X and Y as placeholder. To identify the safety function observe the "S" at the ending of the type identifier.

#### **3.1.2 Connection 1x AC 230 V / 3x AC 230 V**

AGL202-XX1FY-XXXXXXXS

AGL202-XX2FY-XXXXXXXS

AGL202-XX3FY-XXXXXXXS

With X and Y as placeholder. To identify the safety function observe the "S" at the ending of the type identifier.

## 4 Information of Risk Analysis and Risk Assessment

According to the Machinery Directive 2006/42/EC, the manufacturer of a machine is obliged to carry out a risk analysis in order to identify the hazards related to the machine.

The Standard EN 12100 – Safety of machinery - General principles for design - Risk assessment and risk reduction describes the information required for risk assessment.

Risk assessment is effected according to the following criteria:

- degree of injury (serious/minor)
- frequency or duration of stay (frequent/seldom)
- possibilities of avoidance (hardly possible/possible)

For defined risks the Standards EN ISO 13849-1, IEC 61508 or EN 954-1 can be used to accomplish a correct classification into Safety category, SIL (Safety Integrated Level) or PL (Performance Level). These standards contain design principles for safety-relevant parts of control systems.

In the case of the safety function "Safe Torque Off", the risk assessment must consider the fact that the motor will coast to a standstill in the case of an error. Depending on the application, a mechanical brake may be required.

### **Responsibility:**

The **Manufacturer** shall be responsible for the safety of the machine.

- risk analysis of hazards originating from the machine
- measures for reduction and elimination of the risks
- documentation of residual risk from the point of view of the manufacturer
- selection of suitable controller, installation of protective equipment, ergonomics, documentation, warning of remaining risks

The **operator** of the machine is responsible for the safety of the application.

- risk analysis of hazards originating from the use of the machine
- documentation of residual risk from the point of view of the operator
- safe operation and protection of operating staff (barriers, instruction of operating staff, etc.)
- 

Selection of safety function:

- Risk analysis and risk assessment for machine (EN 12100)
- Risk reduction by machine design
- If not possible by design: risk reduction by protective equipment
- Identification of safety requirements
- Selection of category of safety function



## 5 General Description of Safety Function

### 5.1 Integrated Safety Function

Electronic protection systems are integrated in the drive control system and perform safety functions in order to minimize or eliminate hazards caused by functional errors of machines.

The integrated safety functions replace time-consuming and expensive installation of external safety components.

The safety function can be requested or triggered by an error.

In hazard areas, setup work or work for elimination or errors may be required where the safety function is not to be activated by isolating protection devices such as mains contactors or motor contactors. Here, the additional safety function may be used. STO can be used as an alternative to mains or motor contactors, which can be omitted dependent on the application.

The integrated safety functions reduce the risk of personal damage in hazard areas and reduce installation requirements.

### 5.2 Functional Safety

The safety function of the control system must be ensured for normal, trouble-free operating states as well as in the case of an error. As a result of this requirement:

- The safety function must be checked in case errors are present. Possible methods include: fault tree analysis, FMEA, etc.) u. a.

### 5.3 Classification the safety requirement

The integrated safety function "Safe Torque Off" of the AGL frequency inverter meets the following requirements according to EN 61800-5-2:

- up to safety integrity level SIL 2 according to DIN EN 61508 for STO
- up to performance level d according to EN 13849-1
- of category 3 according to EN ISO 13849-1

In the case of an error, thanks to the safety function STO, the frequency inverter does not supply energy to the motor which would cause a revolution or torque (or a movement or force in the case of a linear motor).

Characteristic for the classification mentioned above:

- If an error occurs, the safety function is maintained.

With a suitable external safety control device the function „Safe Stopp 1 (SS1 c)“ according to EN 61800-5-2 can be realized together with the AGL.

By using appropriate safety control devices, stop category 0 and stop category 1 according to EN 60204 can be achieved in the machine. For safety control devices, please refer to chapter 10.

**Stop category 0:** Stop by immediate disconnection of energy supply to the machine drive elements, i.e. uncontrolled stop.

**Stop category 1:** Controlled stop, where energy is still being supplied to the drive elements of the machine to perform the stopping operation. Energy supply is stopped only after the drive has come to a standstill.

Note that the drive may not stop immediately but coast to a standstill. If no mechanical brake is installed, or a defective brake may involve a risk, further protective measures (in example tumbler) are to be taken.

## 6 Description of ACTIVE Cube Safety Function

The frequency inverters of the AGL devices series feature the integrated safety function „Safe torque off, STO“.

With a suitable external safety control device the function „Safe Stopp 1 (SS1 c)“ according to EN 61800-5-2 can be realized together with the AGL.

### Definitions according to EN 61800-5-2:

**STO:** The motor is supplied with no energy, which could cause a rotation (or a movement in a linear motor). The frequency inverter supplies no energy to the motor, which could produce a torque.

**SS1 c:** The system safety relay + frequency converter performs the function of:

Triggering of the motor deceleration and according to an application-specific time a delayed triggering of the STO function. This safety function corresponds to a controlled stop according to EN 60204-1, Stop Category 1.

### Definitions according to EN 60204-1:

**Stop category 0:** Stop by immediate disconnection of energy supply to the machine drive elements, i.e. uncontrolled stop.

**Stop category 1:** Controlled stop, where energy is still being supplied to the drive elements of the machine to perform the stopping operation. Energy supply is stopped only after the drive has come to a standstill.

Stop functions must always have priority over start functions and must work properly in any operation mode.

Resetting of the stop function must not cause any dangerous state.

The mechanical elements must be dimensioned properly for the stop category used. If, for example, a mechanical brake is applied in the case of fast-rotating machines via stop category 0, this brake must be able to stop the machine safely. Wear and tear of the mechanical elements must be considered during projection for the operating states and indicated in the maintenance instructions.

Stop category 0 always has priority over stop category 1.

### 6.1 Definitions of the AGL Safety functions

**SF1:** Safety Function 1

**SF2:** Safety Function 2

**DF1:** Diagnosis function 1

**DF2:** Diagnosis function 2

#### Response time:

Time that elapses between the triggering of the Safety function on the user interface and reaching the safe state.

Example for STO: On the user interface the signal level switches from above DC 15 V to less than DC 5 V. Latest when falling below DC 5 V the response time begins and ends at the moment where torque can no longer be generated.

#### Fault Response time:

Time between the occurrence of a detectable fault and reaching the safe state of the frequency inverter.

Example: The Safety function STO can no longer be triggered via channel A. The device internal diagnosis detects the fault and initiates the necessary fault reaction functions. Overall the Fault response time elapses until torque can no longer be generated.

### 6.2 Specification of the Safety Function 1 (SF1): STO

Type of Safety function SF1 According to EN 61800-5-2:	Safe Torque Off, STO
Active Principle of SF1	Disconnection of energy supply to the motor
Demand rate	High
SIL-Level (IEC 61508)	2

Redundancy	On two channels (2)
Performance Level (EN ISO 13849-1)	d
Kategorie (EN ISO 13849-1)	3
Amount of Processs interfaces	Two (2)
Design of Processs interface	Two yellow marked spring terminals X11.3 and X13.3 (inputs STOA und STOB)
Type of Processs interfaces	SPS-Type 1 compatible according to IEC61131-2
Operation modes with limited functionality of SF 1	None
Response time SF1	Less than or equal to 150 ms
Fault Reaction time DF1	Less than or equal to 220 ms

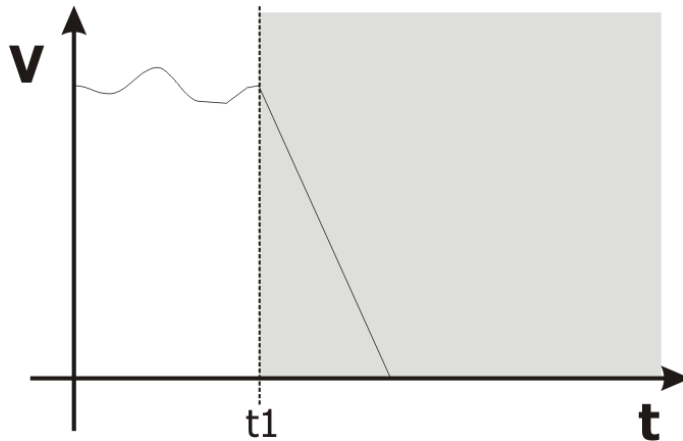



V            Speed axis  
 t            Time axis  
 t1          Time frame, when STO is triggered  
 Area of discontinuation

### 6.3 Specification of the Safety Function 2 (SF2): SS1

Type of Safety function SF2 According to EN 61800-5-2:	Safe Stop 1, SS1 c
Active Principle of SF2	Delay of motor with suitable braking ramp Disconnection of energy supply to the motor after elapsing of a safe time delay
Demand rate	High
SIL-Level (IEC 61508)	2 with suitable safety switching device
Redundancy	On two channels (2)
Performance Level (EN ISO 13849-1)	d with suitable safety switching device
Amount of Processs interfaces	External safety switching device according to requirements of risk analysis Two (2) on AGL
Design of Processs interface	External safety switching device according to requirements of risk analysis Two yellow marked spring terminals X11.3 and X13.3 (inputs STOA und STOB)
Type of Processs interface STO	SPS-Type 1 compatible according to IEC61131-2
Operation modes with limited functionality of SF 2	None
Response time SF2	External safety switching device: according to data sheet of device AGL: Less than or equal to 150 ms
Fault Reaction time DF2	External safety switching device: according to data sheet of device AGL: Less than or equal to 220 ms

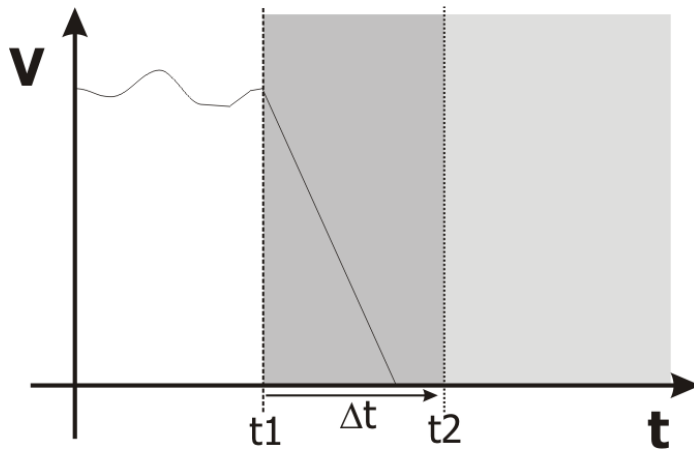
The security function corresponds to a controlled stop to EN 60204-1, Stop Category 1.

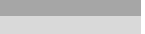

V	Speed axis
t	Time axis
t1	Time frame, when braking ramp is triggered (non safe path)
t2	Time frame, when STO is triggered
$\Delta t$	Time between activation of braking ramp and triggering STO
	Area of maximum braking Time, Set up on external safety control device.
	Area of discontinuation

## 6.4 Description of Safety Function

In the case of an error or if requested, the power semiconductors of the frequency inverter will be switched off. After this, the frequency inverter does not supply energy to the drive which would cause a revolution or a torque (or a movement or force in the case of a linear drive). Mains voltage is still present. If an error occurs, the machine can still be (or remain) switched off safely.

Unlike shut-down via mains contactors or motor contactors, the integrated safety function enables easy combination of drives in a machine to form functional groups. The Safe Torque Off can be limited to certain plant areas in this way. Another advantage is the fact that it is not necessary to wait until the frequency inverter has been charged and discharged. Thus, readiness of the machine for operation can be restored more quickly. Regular electro mechanic equipment are wearing out – through the usage of the STO functionality, this kind of equipment is no longer necessary and maintenance costs can be reduced.

### Safe Torque Off:

- Energy supply for the rotary field of the motor is interrupted; the motor coasts to a standstill
- Used if monitoring for standstill is not required
- Accidental start of the motor is prevented
- No galvanic isolation of motor from frequency inverter DC link

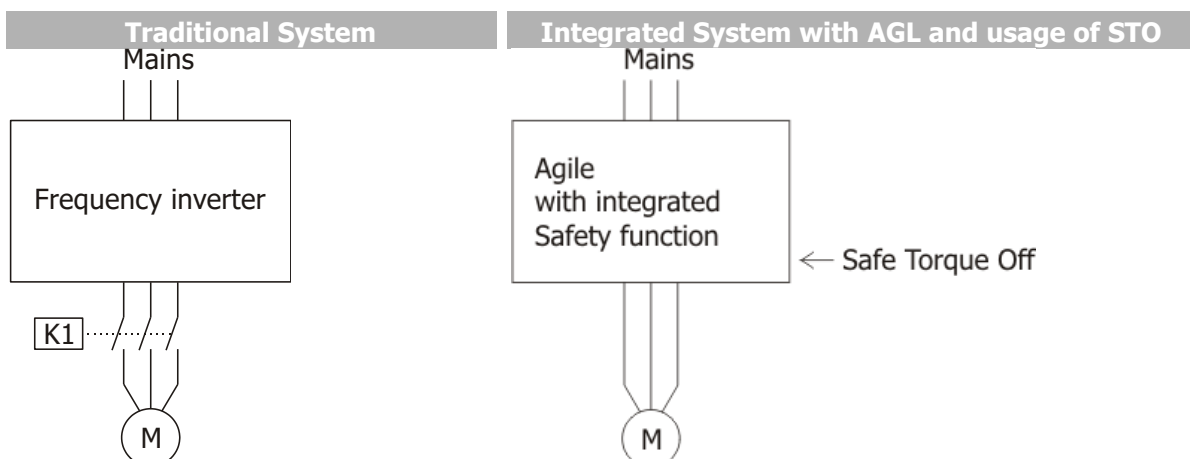

Further advantages:

- Contactors on motor side not required, reduced installation requirements, less components, more space in electrical cabinet
- Simple realization with external safety control device for Stop-Category 0
- With a suitable external safety control a functional safety according to Stop Category 1 can be achieved
- The drive can be connected to power supply continuously; communication and parameter configuration of the frequency inverter are maintained while the torque is disabled With a suitable external safety control device the function „Safe Stopp 1 (SS1 c)“ according to EN 61800-5-2 can be realized together with the AGL.

Easier machine approval, because the safety function is certified via a type examination check.



### Triggering of function "Safe Torque Off"

Safe Torque Off can be achieved by:

- Intentional triggering during operation in order to stop a drive and safely prevent restarting, e.g. for maintenance work on a machine.
- Triggering by actuation of an emergency stop switch or monitoring of protective systems, e.g. safety door.
- Detection of an error. The drive may only start again after the error has been acknowledged and eliminated.

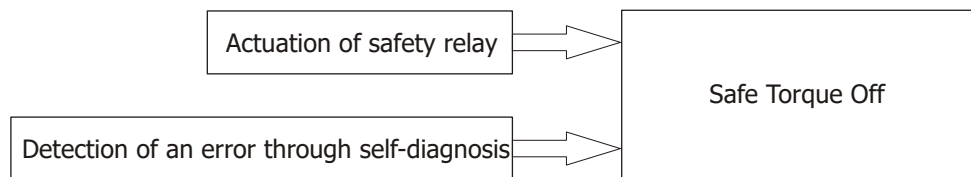

### Application example:

The danger zone near a transport conveyor is monitored by a light grid. If anybody enters the danger zone, the light grid is interrupted. The DC 24 V supply for the digital inputs STO of the function „Safe Torque Off“ is switched off and the frequency inverter output stage is disabled. The drive coasts to a standstill. Disconnection from mains supply is not necessary. Communication via field bus or addressing via the terminals is still possible. An external brake which stops the motor can be addressed.

## 6.5 Two-Channel Monitoring

The STO function (Safe torque off) is realized via two channels in the frequency inverter (redundant design). Via two redundant monitored stop paths with no-voltage release (STOA and STOB), the frequency inverter is switched off safely even if an error occurs and the control voltage fails at the same time. Thus, the drive does not generate further torque. An active movement is not stopped by the function. Externally generated movements (such as a stroke movement by weight) must be switched off safely by external means (for example, mechanical brake).

Triggering can be effected, for example, via a two-channel contactor control with two release circuits and redundant disconnection of the main current or via a sensor or emergency stop switch with two contacts and separate cable routing to the evaluation unit.

Via the digital inputs STOA (X11.3) and STOB (X13.3), two DC 24 V control voltages of a protection device are applied. If the protection device is actuated, the control voltages are interrupted, the energy supply to the motor is switched off. Disconnection is effected at a delay according to chapter 6.2.

If the function STO is triggered, the high level controller (PLC) has no more influence on the inverter release<sup>1</sup> in the frequency inverter. To restart, the inverter release is enabled by the release by the user or by the superior PLC.

An error inside the STO self-monitoring is identified and can then be repaired (e.g. by replacing of a unit). Internally in the device the two stop paths are monitored cyclically beginning with the terminal and ending with the power semiconductor. Both stop paths are designed identically.

One single error will not result in a failure of the safety function.

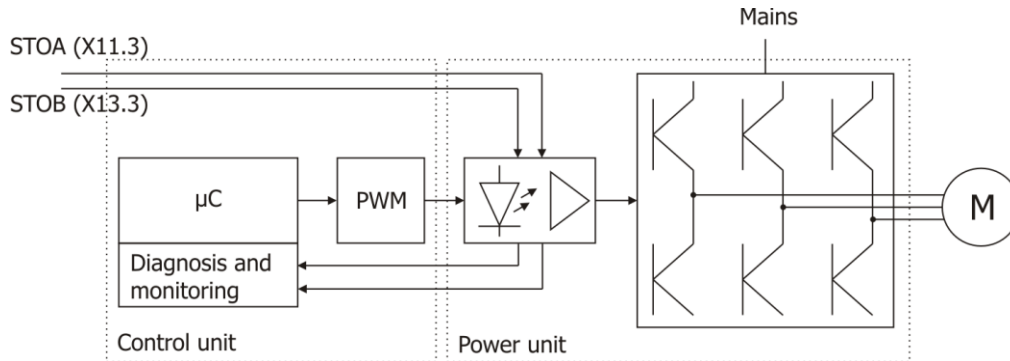

The test required for monitoring is performed by the frequency inverter automatically. If the test results negative, the frequency inverter cannot be switched on anymore. Starting is possible again only after the frequency inverter was completely disconnected from voltage supplies and error has been corrected.

### Truth table

In the truth table, the states of the safety-relevant inputs STOA and STOB for activation and deactivation of the safety function STO are listed.

Truth table		
STOA	STOB	Description of state
0	0	Safety function "Safe Torque Off" (STO) has been triggered. The frequency inverter signals no error in STO function. The inverter release is interrupted.
0	1	STO is triggered. Monitoring for error in frequency inverter or external circuitry (5-second monitoring). After 5 seconds, an error is signaled. The inverter release is interrupted.
1	0	
1	1	STO is not triggered. Release for operation. Only in this state starting signals are accepted by the frequency inverter and lead to a switching of the modulation.

### 5-second monitoring

It will be checked if the two inputs STOA or STOB are switched on within an interval of less than 5 sec for requesting the release of the frequency inverter output stages.

If function STO is triggered by removing one of the signals from inputs STOA or STOB, the status changes to "STO triggered" and the output stage is inhibited. In this state the monitoring function checks, that during the next 5 seconds the second input is switched off. If this has not been done within 5 s after occurrence of this state, an error is triggered (5-second monitoring).

- Different signal states on inputs STOA or STOB start the 5-second monitoring
- Within 5 seconds, the same signal must be present of both inputs, otherwise an error will be signaled (**F1205**)
- If the STO function is triggered on one channel, in the next following 5 s the STO function must be triggered on both channels.

The error **F1205** can be acknowledged using the Fault reset to reset the drive.

Behavior of frequency inverter after start

<sup>1</sup> If the inverter release is interrupted, a motor revolving field can no longer be generated in this state.

- Initialization
- Monitoring for release request (5-second monitoring)
- Preparation of release (check of stop paths)
- Release of frequency inverter

Behavior of frequency inverter in the case of an error

- Switch off of IGBT in power output stage by disconnection of optocoupler supply voltage
- Suppression of control pulses of IGBT
- Setting of error bit with possibility of transfer to overriding controller
- Setting of digital output for error message
- Release of digital input for error acknowledgement.

## **6.6 Diagnosis function and enforced dynamizing**

The test required for monitoring the stop paths is performed by the frequency inverter automatically. Via automated enforced dynamizing, the stop paths are checked for errors. If the test result is negative, the frequency inverter cannot be switched on anymore, and an error of the group "F12" (in example F1201) is signaled. Starting is possible again only after the frequency inverter was completely disconnected from voltage supplies and error has been corrected.

## 7 Requirements to be met by installation

### 7.1 Instructions on installation of safety equipment

- If work is to be carried out on live components, it must be possible to disconnect the machine from mains supply by means of a main switch.
- According to EN 61800-5-2 a fault exclusion can be considered with one of the following possibilities:
  - The conductor is installed permanently and in example protected against external damage with a cable duct or reinforcement.
  - Single multi-conductors are used.
  - The conductors are situated in an electrical cabinet.
  - The conductors are shielded independently and have grounding.
- If applicable, the requirements of EN 60204-1 have to be considered to install the connectors correctly.
- Protection against dirt is ensured if the frequency inverter and safety control equipment is installed in electrical cabinets with high IP protection, e.g. IP 54.
- If external forces act on the drive axis, e.g. in the case of vertical axes (suspended loads) or round axes with asymmetrical weight distribution, mechanical brakes must be installed additionally.
- Only use voltage sources with safe disconnection (SELV/PELV) according to VDE0100. Comply with the specifications in chapter 7.3 .
- The STO inputs may be controlled with pulsed signals, neg. Pulse lengths < 500  $\mu$ s.
- Errors can be excluded in the case of the Agile units because the terminal blocks for the STO function are physically separate from one another. The signal cables between the safety control equipment and ACTIVE Cube must either be physically separate from one another or suitable, cross fault proof cables.
- Comply with applicable EMC instructions mentioned in the operating instructions.
- After installation, check the safety function and error reaction and issue an acceptance report.
- Interrupting the STO signals prevents a start of the motor. According to EN 60204-1, STO must not be released during an impending endangerment.
- Also comply with the instructions on external safety control equipment.
- During commissioning, check the safety function.

Select the dimensions of the safety application such that the input current according to the operating instructions is available for each of the inputs STOA and STOB (typical: 10 mA). If more than one Agile frequency inverters are connected to one safety control device, the safety control device must provide sufficient power for all of them.

### 7.2 External Safety Control Equipment

Safety control equipment, upon request (e.g. actuation of emergency stop or access to hazard area, must trigger appropriate responses in order to protect people, the machine and the environment. They evaluate sensor signals or safely switch off dangerous states.

External safety control devices must meet the following requirements:

- External safety control equipment and safety modules for control of the digital inputs (STO) must meet one of the following classifications, to meet the classification of the AGL device:
  - PL d according to EN ISO 13849-1
  - SIL 2 according to IEC 61508
  - the whole installation meets these requirements.
- The switching capacity of the safety control equipment must be designed for the maximum permissible, limited output current of the DC 24 power supply. Comply with the instructions of the manufacturer of the safety control equipment on the permissible contact load and any safeguards to be provided for the safety contacts.
- The emergency stop device must comply with Standard EN ISO 13850.
- If a safety request (e.g. emergency stop actuated or sensor signals that safety door is open) is reset (emergency stop unlocked, safety door closed) this alone shall not result in a restart of the drive. Restart may only occur after the safety control device has been reset.

External safety control devices evaluate sensors:



Examples of contact sensors:

- Emergency stop control device for stop in dangerous situations
- Position switch, e.g. for monitoring slide doors, safety grids or moving machine parts

Examples of no-contact sensors:

- Light barriers, e.g. for monitoring areas with dangerous movements
- Light curtains

### 7.3 External DC 24 V power supply



#### CAUTION

Use a suited SELV/PELV voltage supply, which rated voltage has to be DC 24 V  $\pm 10\%$ . The largest overvoltage must not exceed DC 32 V in the case of a fault (one fault safety). The one fault safety has to be realized with an overvoltage protection of the mains supply (overvoltage protection OVP with limiting the output voltage to a maximum of DC 32 V) or an external wiring like a Crowbar. An adequate overvoltage category of the voltage supply has to be ensured.

During projection and installation of a DC 24 V supply connected to the frequency inverter comply with the following instruction. This also includes supply of a safety control device the output of which is connected to a control input (including STOA and STOB) of the frequency inverter.

#### 7.3.1 External DC 24 V voltage supply for group stop

When multiple frequency inverters should be switched off by on DC 24 V voltage supply, the overall current consumption of the STO inputs must be determined.

Please check the operating instructions for the current consumption.

Typical is 10 mA for each STO input for each device.

Dimension the cable cross sections according to the calculated current in compliance with the maximum connectable cable cross sections.

### 7.4 DC 24 V power supply by AGL

You can use terminal X11.1 (DC 24 V supply) and X11.2 (GND) in order to supply a safety control device. Only use the power supply for the device connected to the frequency inverter. Other safety control devices **must not** be connected. The maximum output current is 100 mA.

All further connected components (in example displays of digital outputs) and the safety control device must not have higher current requirements.

## 8 Requirements to be met in operation

During operation, the projected and commissioned machine components must not be changed. If the machine is modified a new acceptance inspection is required.

Check the safety function at regular intervals. The test intervals are to be determined according to the risk analysis. However, the check should be performed once every year, at the latest.

## **9 Requirements to be met by acceptance inspection**

The acceptance inspection of the safety function is ordered by the manufacturer of the machine. The inspection (acceptance, validation) shall be performed by a properly qualified person.

The result of the inspection is to be documented and must be signed by the inspector. Each safety function must be documented in detail in this report.

The inspections also include the machine documentation, including its safety functions. The safety functions must be checked particularly during the inspection and documented in the inspection report. Parameter settings shall be attached to the report. Further documents shall be added, as required, depending on the machine.

Depending on the result of the risk analysis, inspection reports of the regular inspections shall be issued and signed by the inspector.

## 10 Application Examples

The following examples illustrate how the functions "Safe Torque Off (STO)" and "Safe Stop 1 (SS1)" work. According to EN 60204, stop functions are divided in different categories. By suitable safety control devices, stop categories 0 and 1 can be realized in combination with the frequency inverter AGL.

### 10.1 STO according to Stop Category 0

#### 10.1.1 STO Direct Stop

The Application example shows the minimum circuitry for Agile Frequency inverter for realization of the safety function STO – "Safe Torque Off" with an emergency stop device in a common electrical cabinet according to EN ISO 13849-1 PL d and Category 3 or IEC 61508 SIL 2.

When operating the emergency stop device with two stop channels both release paths STOA and STOB of the Agile frequency inverter are interrupted and the integrated safety function is triggered by interrupting the inverter release. A (non-safe) feedback to a process control can be done via a connected field bus. When STO is requested, the process controller can no further influence the inverter release inside the frequency inverter.



Terminal X11.1 can be used for DC 24 V supply of the safety control unit. Please comply with chapter 7.3.1.

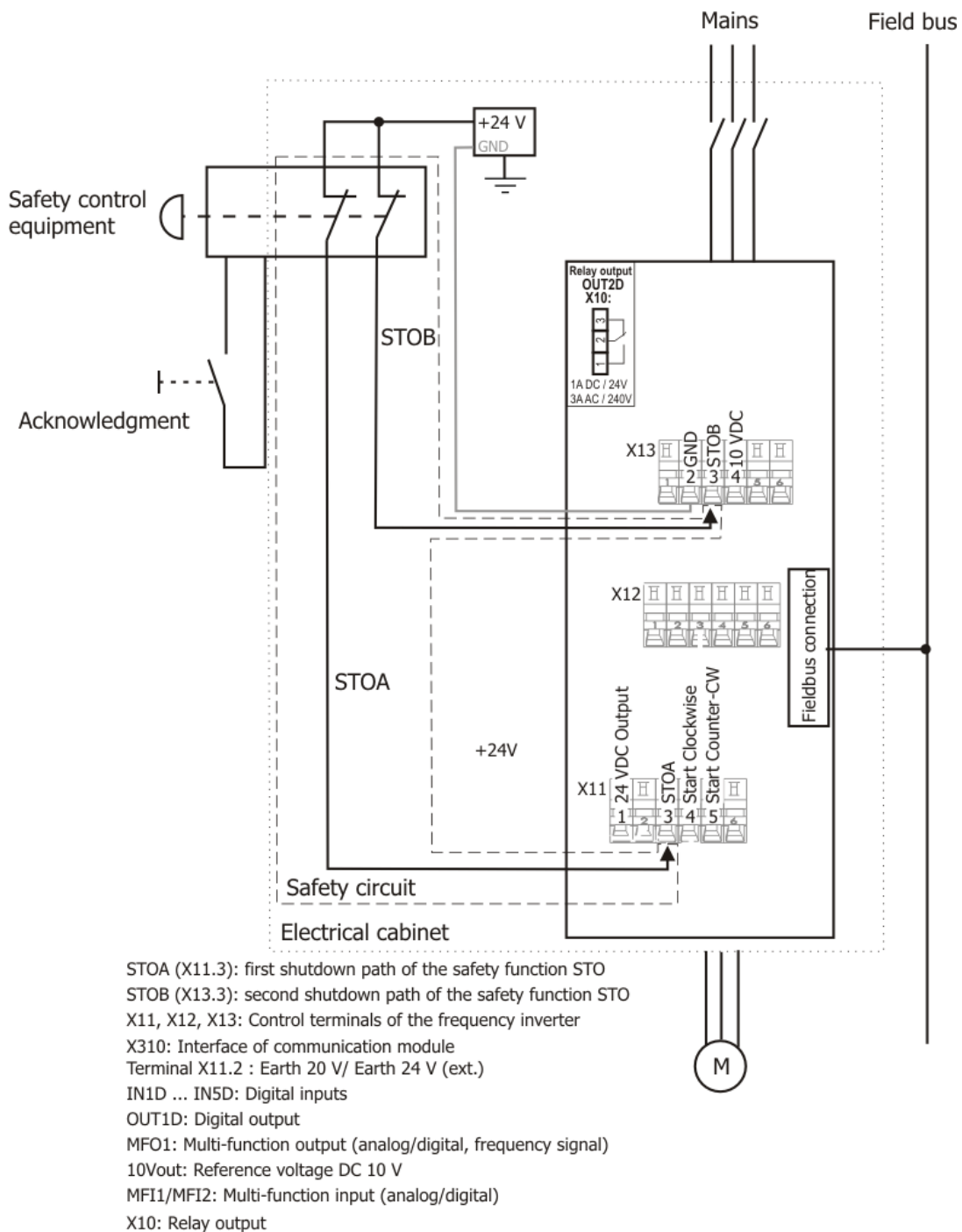

### 10.1.2 STO Direct Stop with error exclusion "short circuit" in the cabinet

The application circuit shows a drive control system with safety module according to EN ISO 13849-1 PL d and Category 3 or IEC 61508 SIL 2. Safety control equipment with one enable path and interconnection line is implemented instead of safety control equipment with two enable paths.

Comply with the following conditions:

- Safety control equipment and inverter have to be placed in the same cabinet.
- Error exclusion in case of short circuit has to be ensured for wiring between safety control equipment and inverter (for example insulated conductor).

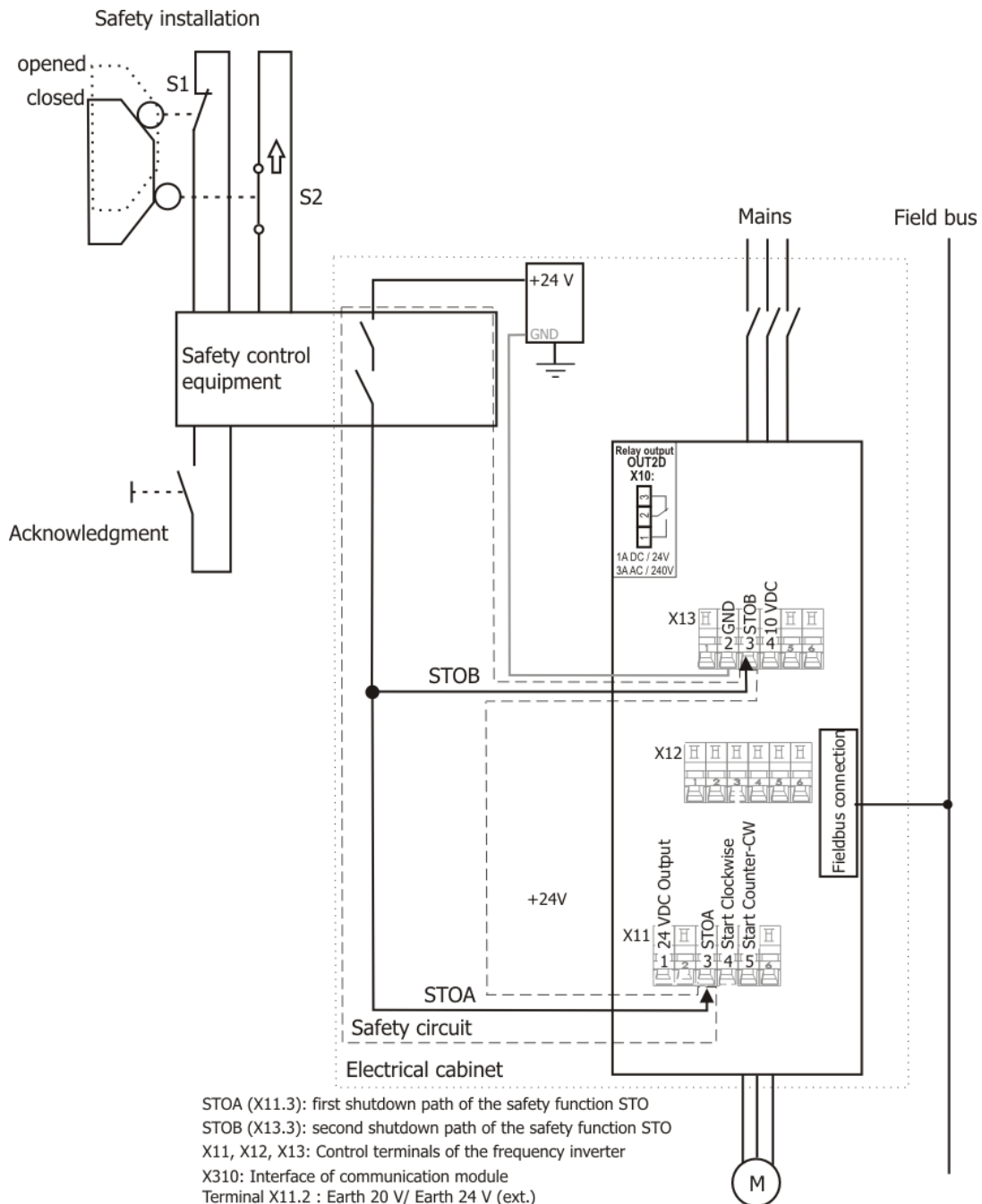

STOA (X11.3): first shutdown path of the safety function STO  
 STOB (X13.3): second shutdown path of the safety function STO  
 X11, X12, X13: Control terminals of the frequency inverter  
 X310: Interface of communication module  
 Terminal X11.2 : Earth 20 V/ Earth 24 V (ext.)  
 IN1D ... IN5D: Digital inputs  
 OUT1D: Digital output  
 MFO1: Multi-function output (analog/digital, frequency signal)  
 10Vout: Reference voltage DC 10 V  
 MF11/MF12: Multi-function input (analog/digital)  
 X10: Relay output

### 10.1.3 STO Direct Stop with Feedback to PLC

The application example shows a drive control system with PLC and safety module according to EN ISO 13849-1 PL d and category 3 or IEC 61508 SIL 2. A PLC performs the process control of the frequency inverter and can start the drive profiles via commands.

If the protective device is actuated, e.g. safety door open, the release paths of the safety module are interrupted.

Through the interruption of the control voltages on stop paths STOA and STOB of the frequency the integrated safety function with SIL 2 according to EN-61800-5-2 is activated by interrupting the inverter release.

The safety module monitors the function of the switches S1 and S2 which are located outside of the electrical cabinet.

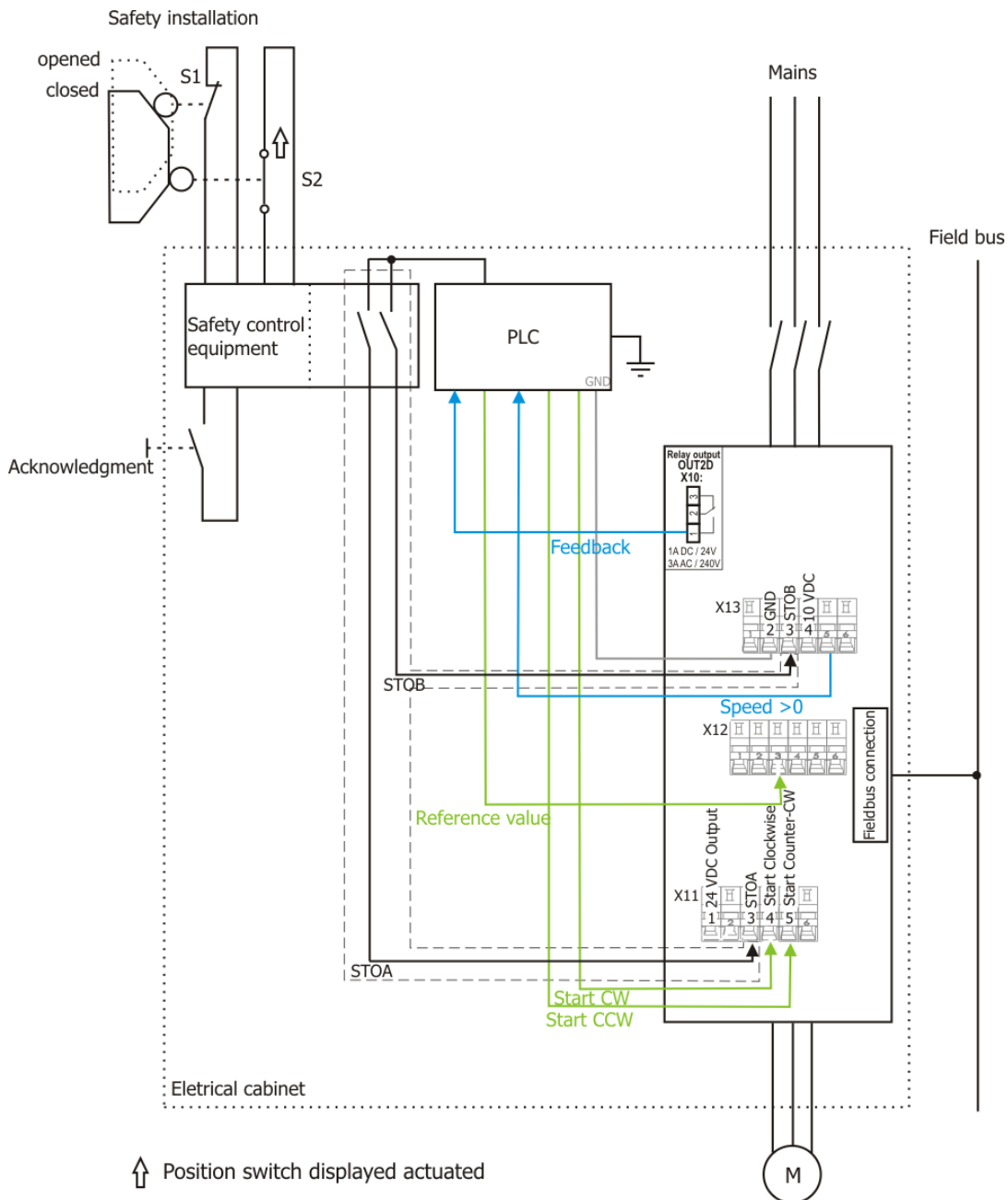

### 10.1.4 STO Direct Stop w/ Feedback to PLC w/ error exclusion "short circuit" in cabinet

The application circuit shows a drive control system with PLC and safety module according to EN ISO 13849-1 PL d and Category 3 or IEC 61508 SIL 2. Safety control equipment with one enable path and interconnection line is implemented instead of safety control equipment with two enable paths.

Comply with the following conditions:

- Safety control equipment and inverter have to be placed in the same cabinet.
- Error exclusion in case of short circuit has to be ensured for wiring between safety control equipment and inverter (for example insulated conductor).



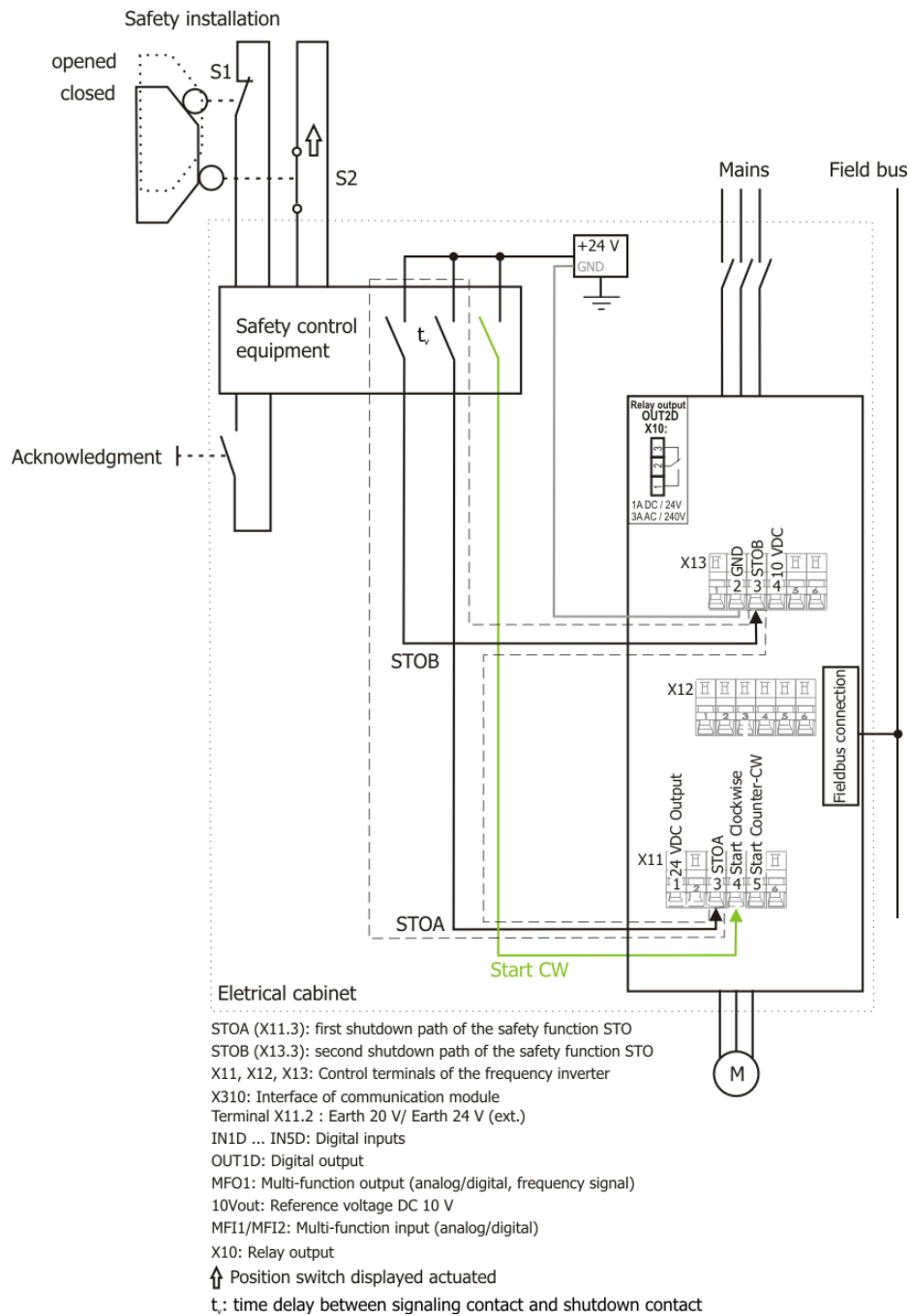

### 10.2.2 SS1 Direct Stop with error exclusion "short circuit" in the cabinet

The application circuit shows a drive control system according to EN ISO 13849-1 PL d and Category 3 or IEC 61508 SIL 2 with PLC and safety module. Safety control equipment with one enable path and interconnection line is implemented instead of safety control equipment with two enable paths.

Comply with the following conditions:

- Safety control equipment and inverter have to be placed in the same cabinet.
- Error exclusion in case of short circuit has to be ensured for wiring between safety control equipment and inverter (for example insulated conductor).



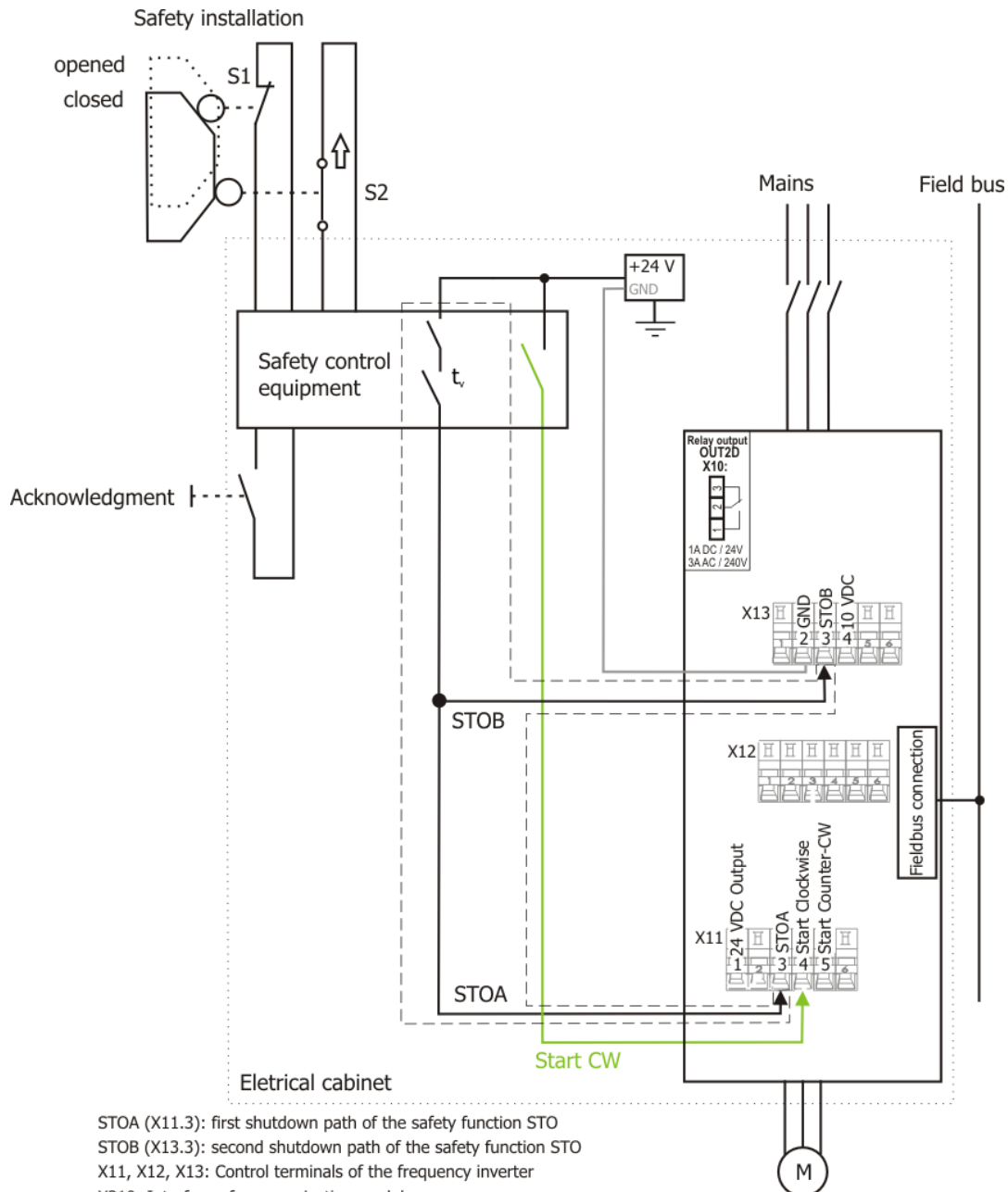

- STOA (X11.3): first shutdown path of the safety function STO
- STOB (X13.3): second shutdown path of the safety function STO
- X11, X12, X13: Control terminals of the frequency inverter
- X310: Interface of communication module
- Terminal X11.2 : Earth 20 V/ Earth 24 V (ext.)
- IN1D ... IN5D: Digital inputs
- OUT1D: Digital output
- MFO1: Multi-function output (analog/digital, frequency signal)
- 10Vout: Reference voltage DC 10 V
- MF11/MF12: Multi-function input (analog/digital)
- X10: Relay output
- ↑ Position switch displayed actuated
- t<sub>v</sub>: time delay between signaling contact and shutdown contact

### 10.2.3 SS1 Direct Stop with Feedback to PLC

The application example shows a drive control system with PLC and safety module according to EN ISO 13849-1 PL d and category 3 or IEC 61508 SIL 2. A PLC performs the process control of the frequency inverter and can start the drive profiles via commands.

If the protective device is actuated, e.g. safety door open, the release paths of the safety module are interrupted.

The PLC is triggered first, that the safety function was actuated, which then decelerates the motor by resetting the start command ("Start CW" or "Start CCW"). After the delay time  $t_v$  has elapsed the control terminals connected to STOA and STOB interrupt the inverter release of the inverter and the internal safety function STO is triggered by interrupting the inverter release.

The safety module monitors the function of the switches S1 and S2 which are located outside of the electrical cabinet.

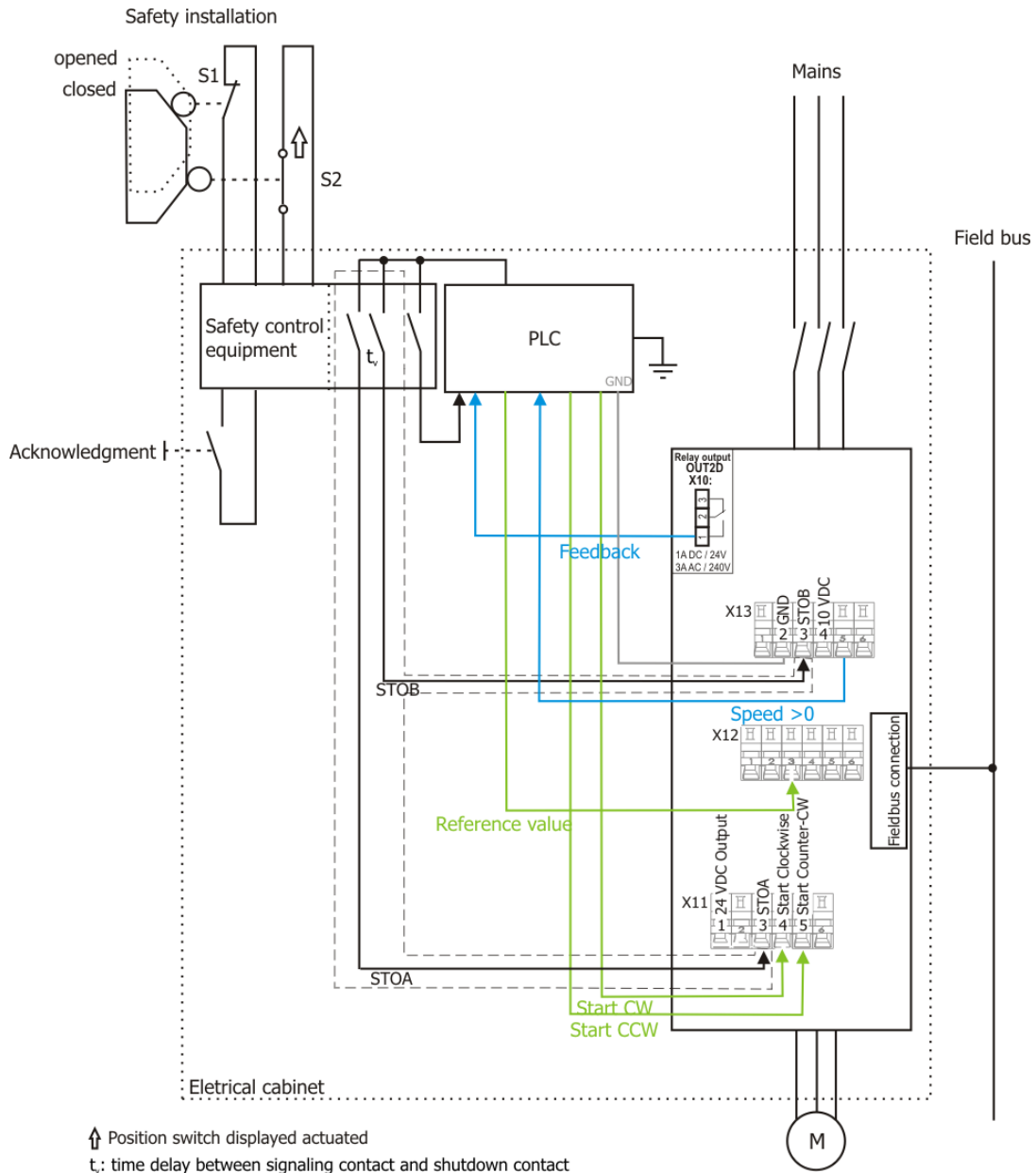

### 10.2.4 SS1 Direct Stop w/ Feedback to PLC w/ error exclusion "short circuit" in cabinet

The application circuit shows a drive control system with PLC and safety module according to EN ISO 13849-1 PL d and Category 3 or IEC 61508 SIL 2. Safety control equipment with one enable path and interconnection line is implemented instead of safety control equipment with two enable paths.

Comply with the following conditions:

- Safety control equipment and inverter have to be placed in the same cabinet.
- Error exclusion in case of short circuit has to be ensured for wiring between safety control equipment and inverter (for example insulated conductor).

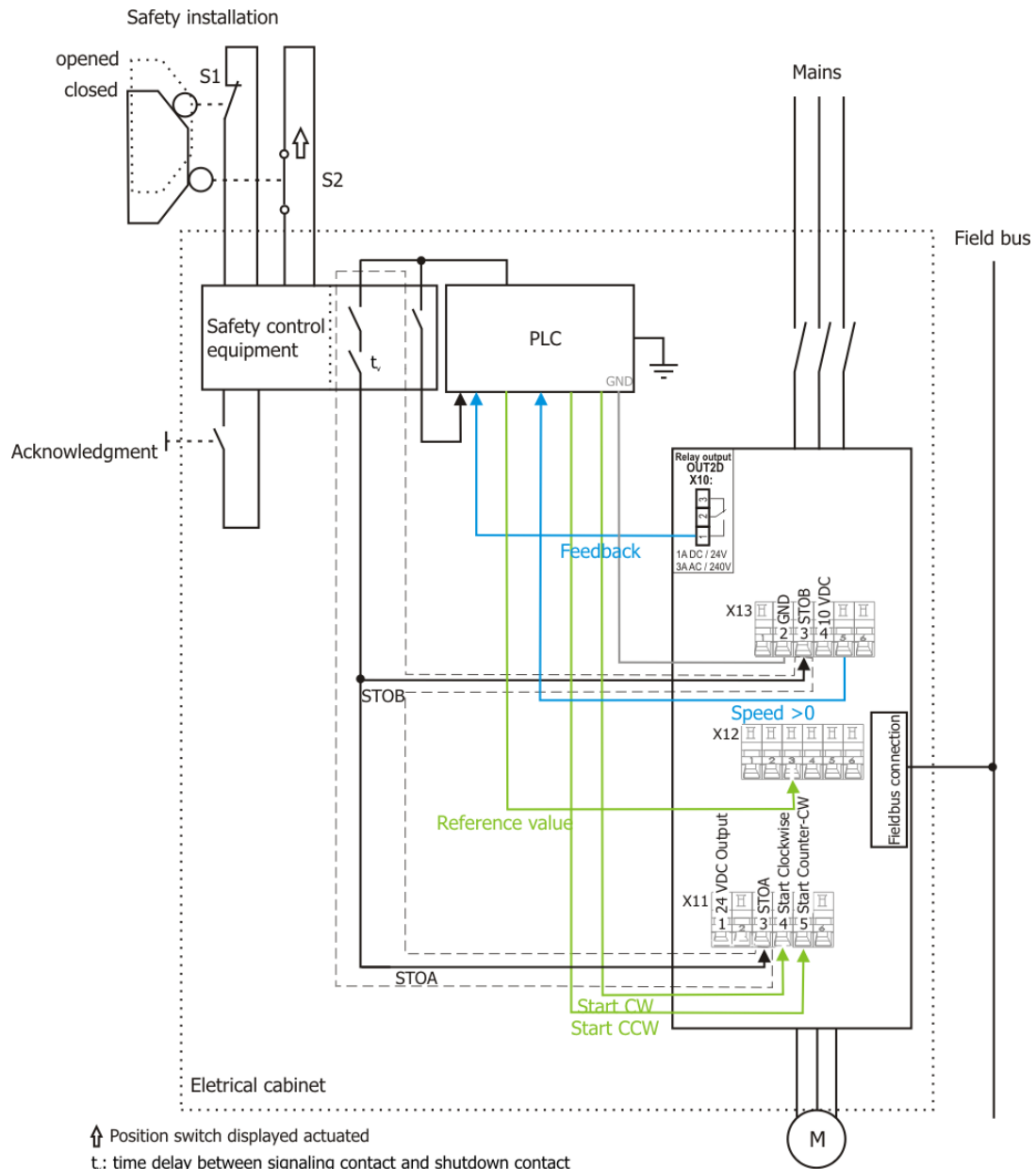

### 10.2.5 Internal DC 24 V Supply, SS1

The application example shows the minimum circuitry for ACTIVE cube frequency inverters for realization of the safety function with an emergency stop switch in a common electrical cabinet. Supply of the safety control device is effected by the internal DC 24 V supply (max. 100 mA for all connected consumers).

When the emergency stop switch is actuated, the travel command "Clockwise" is reset first. After a delay  $t_v$ , the contacts on the safety switch interrupt the two enable paths STOA and STOB of the ACTIVE Cube frequency inverter and the integrated safety function is triggered by interrupting the inverter release.

The delay time is set on the safety control device and must be selected according to the application. The set delay time has to be slightly higher than the shut down time.

A (non-safe) feedback to a process controller can be effected, for example, via a connected field bus. If STO is requested, the overriding controller has no more influence on the pulse block in the frequency inverter.

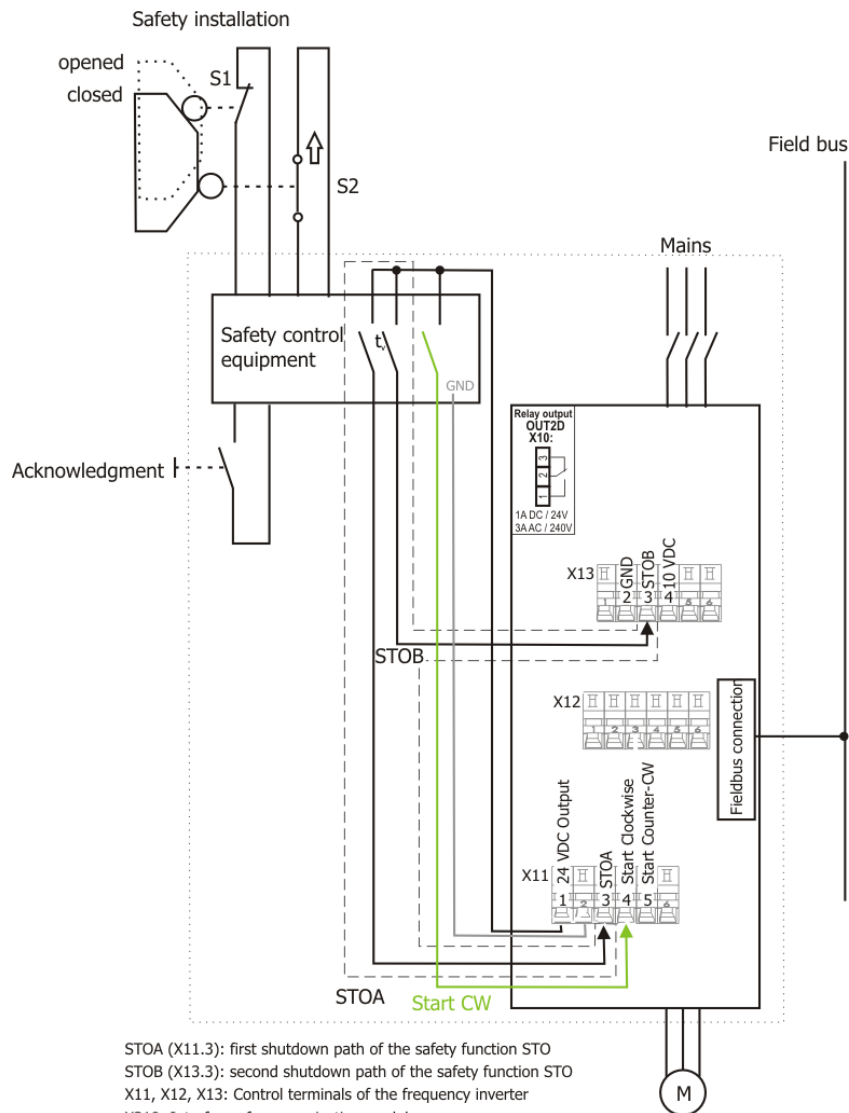

STOA (X11.3): first shutdown path of the safety function STO  
 STOB (X13.3): second shutdown path of the safety function STO  
 X11, X12, X13: Control terminals of the frequency inverter  
 X310: Interface of communication module  
 Terminal X11.2 : Earth 20 V/ Earth 24 V (ext.)  
 IN1D ... IN5D: Digital inputs  
 OUT1D: Digital output  
 MFO1: Multi-function output (analog/digital, frequency signal)  
 10Vout: Reference voltage DC 10 V  
 MF11/MF12: Multi-function input (analog/digital)  
 X10: Relay output  
 ↑ Position switch displayed actuated  
 t: time delay between signaling contact and shutdown contact

### 10.3 Group Stop, SS 1

The application circuit shows a drive control system with PLC and safety module according to EN ISO 13849-1 PL d and Category 3 or IEC 61508 SIL 2. A PLC performs the process control of the frequency inverter and can start the drive profiles via commands which are communicated through the field bus.

If the protective device is actuated, e.g. emergency stop switch, the enable paths of the safety module are interrupted. At first, the travel signal "Clockwise" is reset. Then, the motors are decelerated in a controlled way. After a delay  $t_v$ , the controller enable signal of the frequency inverters is interrupted via the disconnection of the control voltages from STOA and STOB and the integrated safe pulse block is activated.

Via the field bus, the (non-safe) feedback is transmitted to the PLC indicating that the drives have stopped. Except for the terminals shown in the diagram, no further terminals are required for connection.

Note, that with high current demand a fuse leading to the safety contacts might be necessary according to the instructions of the safety device manufacturers.

The external DC 24 V supply must be dimensioned accordingly, see chapter 7.3.1.

In group stop setups pulsed signals could lead to more frequent false positives.

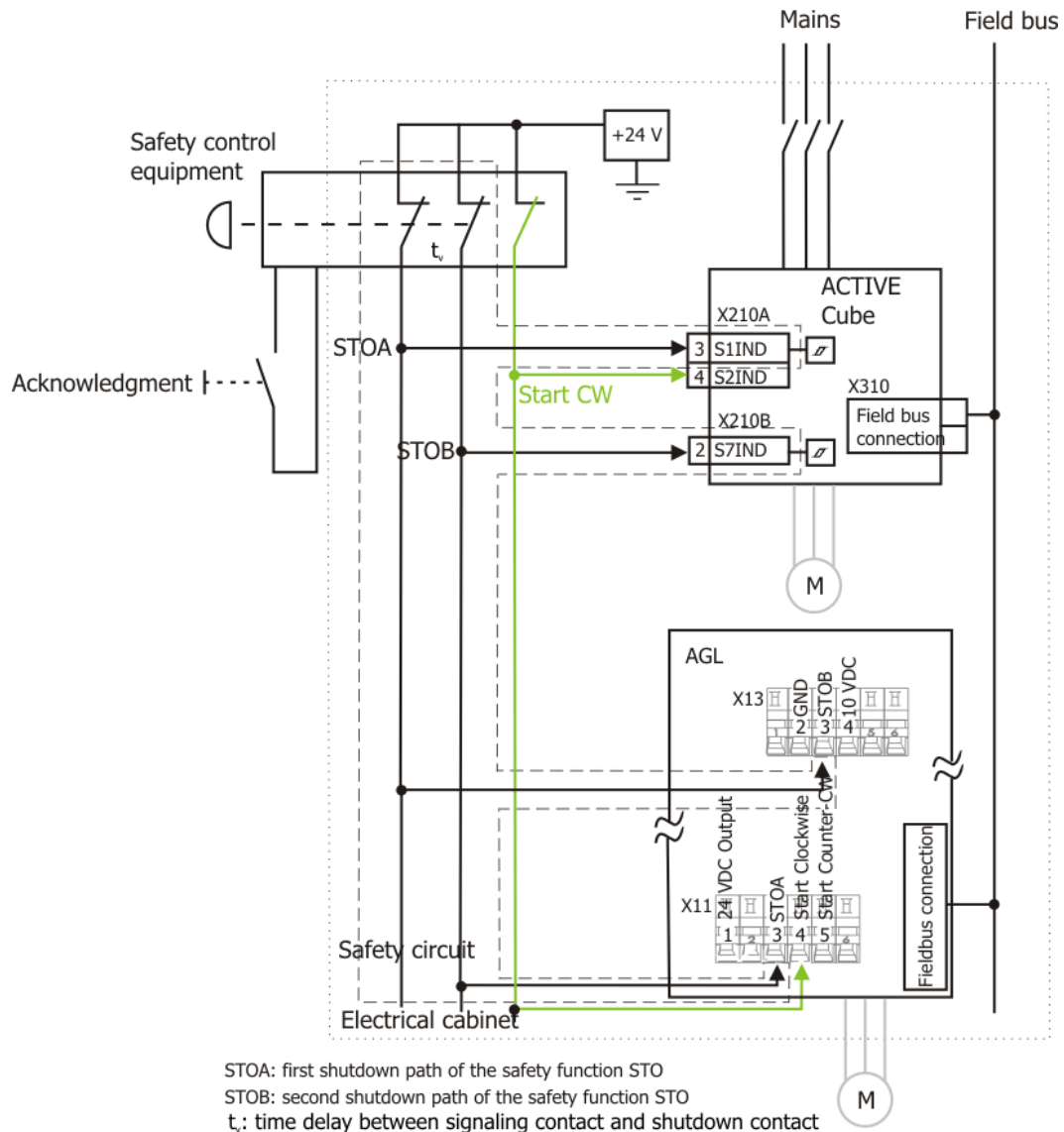

## 10.4 Checklist

This list provides an overview of the requirements to be met in installation, commissioning and operation of the safety function. Depending on the application, additional requirements must be met. Complete this list according to your application.

### Risk analysis:

- was performed?
- requires the use of the safety function "Safe Torque Off"
- requires category 3 according to the following classifications:
  - PL d (or smaller) according to EN ISO 13849-1
  - Category 3 (or smaller) according to EN ISO 13849-1
  - SIL 2 (or smaller) according to IEC 61508
- considers the stopping behavior of the Agile frequency inverter
- permits coasting of the drive to a standstill or requires the installation of a mechanical brake.
- considers the access time to the hazard area
- defines intervals for regular functional checks of the safety function

### Installation:

- EMC instructions in the operating instructions considered?
- The DC 24 V supply was selected and installed based on the requirements of this manual?
- The shield of the 24 V power supply was connected on both sides?

- Emergency stop devices meet the following classifications:
  - PL d (or smaller) according to EN ISO 13849-1
  - Category 3 (or smaller) according to EN ISO 13849-1
  - SIL 2 (or smaller) according to IEC 61508
- Emergency Stop devices have a cross fault monitoring (2-channel connection) or protected wiring?
- It is ensured that resetting of the safety control device alone does not result in a restart of the drive.
- It is ensured that no voltage higher than DC 30 V can occur on the terminals of the control electronic unit (voltage resistance)
- The protection against unexpected restart is set up.

**Commissioning:**

- Functional check of safety function performed?
- Wiring of safety components checked?
- Acceptance report issued?

**Operation:**

- The machine must be operated only inside the specified limits.
- The safety function is checked regularly.

## 11 Safety Function Test Report

The safety function STO (Safe Torque Off) described in this manual was assessed and certified by TÜV Rheinland Industrie Service GmbH.

<b>Test institute</b>	TÜV Rheinland Industrie Service GmbH
<b>Test report no.</b>	968/M 355.01/17
<b>Test sample</b>	Frequency inverter Agile series, concept inspection
<b>Basis of test</b>	IEC 61508 Teil 1-7:2010 (as far as applicable)
	EN ISO 13849-2:2008 + AC:2009 (as far as applicable)
	EN 62061:2005
	EN 61800-5-1:2007
	EN 61800-5-2:2007
	EN 61800-3:2004
	EN 60204-1:2006 + A1:2009 + AC:2010
<b>Assessment</b>	The Assessment leads to the result, that the safety function STO in the frequency inverter series AGLx S complies with the requirements of relevant standards (Category 3 and PL d according to EN ISO 13849-1 and SIL CL 2 according to EN 62061 / IEC 61508 / EN 61800-5-2).  The instructions of the associated Installation and Operating Manual shall be considered.

### 11.1 Characteristical Data

The following data were obtained in the test concept. These data can be used to determine the security requirements with the frequency inverter as part component.

IEC 61508-1 to -7 and IEC 62061

Safety Integrity Level	SIL CL2
PFH [1/h]:	1,5E-11

EN ISO 13849

Performance Level	PL d
Category	Cat. 3
MTTFd	High
Diagnostic Coverage	Medium (90-99 %)

## 12 STO status (diagnosis)

The actual value *STO Status* **277** can be used for an extended diagnosis of the two inputs STOA and STOB. The states of the inputs are displayed bit coded.

Bit	Significance	Description
0	1	Input STOA missing
1	2	Input STOB missing
2	4	Input STOA switch off
3	8	Input STOB switch off
4	16	Timeout STOA
5	32	Timeout STOB
6	64	Diagnosis fault
7	127	FI fault (error)

## **13 Change index**

AGL-STOV0-01SV0-06: General and Safety instructions adapted to actual Bonfiglioli Vectron documentations, information in chapter 3 according to EN 60204 revised.

AGL-STOV0-01SV0-05: First release in English language.



## INDEX

### A

Application example SS1	
1. Direct Stop .....	31
2. Direct Stop with error exclusion .....	32
3. Direct Stop with Feedback to PLC.....	33
4. Direct Stop with Feedback to PLC and error exclusion.....	34
5. SS1 and DC 24 V intern .....	35
6. Group Stop.....	36

### Application example STO

1. Direct Stop .....	27
2. Direct Stop, error exclusion .....	28
3. Feedback to PLC.....	29
4. Direct Stop with Feedback to PLC and error exclusion.....	30

### Approved Devices .....

	15
--	----

### C

Checklist .....	37
Classification safety requirement .....	17
Copyright.....	6

### D

DC 24 V Supply .....	25
Decommissioning .....	12
Designated use.....	7
Diagnosis function.....	23

### E

Electrical connections .....	11
Enforced dynamizing.....	23

### F

Fault exclusion .....	24
FMEA.....	17
Font style.....	10

### I

Installation .....	11
Requirements .....	24
Instruction manuals .....	5

### M

Machinery Directive .....	16
---------------------------	----

### O

One fault safety.....	25
-----------------------	----

### P

PELV .....	25
------------	----

PL 16

Power supply	
external, DC 24 V .....	25
internal, DC 24 V by AGL.....	25

### R

Risk Analysis .....	16
Risk Assessment .....	16

### S

Safe Stop 1 (SS1 c).....	17
--------------------------	----

### Safety

General .....	7
---------------	---

### Safety Control Equipment

External.....	24
---------------	----

Safety function .....	14
-----------------------	----

### Safety Function

Integrated .....	17
------------------	----

Test Report .....	39
-------------------	----

### Safety Function

Description .....	18
-------------------	----

### Safety Function

Two-Channel Monitoring.....	21
-----------------------------	----

SELV.....	25
-----------	----

Service.....	12
--------------	----

SIL.....	16
----------	----

### Standard

EN 60204-1 .....	24
------------------	----

EN 61800-5-2 .....	24
--------------------	----

EN ISO 13850 .....	24
--------------------	----

### Standards

EN 12100 .....	16
----------------	----

EN 60204 .....	17
----------------	----

EN 61800-5-2 .....	17
--------------------	----

EN ISO 13849-1 .....	16
----------------------	----

IEC 61508 .....	16
-----------------	----

### T

Test Report.....	39
------------------	----

### U

Unexpected Restart .....	37
--------------------------	----

### V

Validation .....	37
------------------	----

### W

Warranty and liability .....	6
------------------------------	---

---

# Bonfiglioli worldwide network.

---

## **Bonfiglioli Australia**

2, Cox Place Glendenning NSW 2761  
Locked Bag 1000 Plumpton NSW 2761  
Tel. (+ 61) 2 8811 8000 - Fax (+ 61) 2 9675 6605  
www.bonfiglioli.com.au - sales@bonfiglioli.com.au

## **Bonfiglioli Brazil**

Travessa Cláudio Armando 171 - Bloco 3  
CEP 09861-730 - Bairro Assunção  
São Bernardo do Campo - São Paulo  
Tel. (+55) 11 4344 1900 - Fax (+55) 11 4344 1906  
www.bonfigliolidobrasil.com.br  
bonfigliolidobrasil@bonfiglioli.com

## **Bonfiglioli Canada**

2-7941 Jane Street - Concord, Ontario L4K 4L6  
Tel. (+1) 905 7384466 - Fax (+1) 905 7389833  
www.bonfigliolicanada.com  
sales@bonfigliolicanada.com

## **Bonfiglioli China**

19D, No. 360 Pu Dong Nan Road  
New Shanghai International Tower  
200120 Shanghai  
Tel. (+86) 21 5054 3357 - Fax (+86) 21 5970 2957  
www.bonfiglioli.cn - bdssales@bonfiglioli.com.cn

## **Bonfiglioli Deutschland**

Sperberweg 12 - 41468 Neuss  
Tel. (+49) 02131 2988-0  
Fax (+49) 02131 2988-100  
www.bonfiglioli.de - info@bonfiglioli.de

## **Bonfiglioli España**

TECNOTRANS BONFIGLIOLI S.A.  
Pol. Ind. Zona Franca sector C, calle F, nº6  
08040 Barcelona  
Tel. (+34) 93 4478400 - Fax (+34) 93 3360402  
www.tecnotrans.com - tecnotrans@tecnotrans.com

## **Bonfiglioli France**

14 Rue Eugène Pottier BP 19  
Zone Industrielle de Moimont II  
95670 Marly la Ville  
Tel. (+33) 1 34474510 - Fax (+33) 1 34688800  
www.bonfiglioli.fr - btf@bonfiglioli.fr

## **Bonfiglioli India**

PLOT AC7-AC11 Sidco Industrial Estate  
Thirumudivakkam - Chennai 600 044  
Tel. +91(0) 44 24781035 - 24781036 - 24781037  
Fax +91(0) 44 24780091 - 24781904  
www.bonfiglioliindia.com - bonfig@vsnl.com

## **Bonfiglioli Italia**

Via Sandro Pertini lotto 7b  
20080 Carpiano (Milano)  
Tel. (+39) 02 985081 - Fax (+39) 02 985085817  
www.bonfiglioli.it  
customerservice.italia@bonfiglioli.it

## **Bonfiglioli New Zealand**

88 Hastie Avenue, Mangere Bridge, Auckland  
2022, New Zealand - PO Box 11795, Ellerslie  
Tel. (+64) 09 634 6441 - Fax (+64) 09 634 6445  
npollington@bonfiglioli.com.au

## **Bonfiglioli Österreich**

Molkereistr 4 - A-2700 Wiener Neustadt  
Tel. (+43) 02622 22400 - Fax (+43) 02622 22386  
www.bonfiglioli.at  
info@bonfiglioli.at

## **Bonfiglioli South East Asia**

No 21 Woodlands industrial park E1  
#02-03 Singapore 757720  
Tel. (+65) 6893 6346/7 - Fax (+65) 6893 6342  
www.bonfiglioli.com.au  
sales@bonfiglioli.com.sg

## **Bonfiglioli South Africa**

55 Galaxy Avenue,  
Linbro Business Park - Sandton  
Tel. (+27) 11 608 2030 OR - Fax (+27) 11 608 2631  
www.bonfiglioli.co.za  
bonfigsales@bonfiglioli.co.za

## **Bonfiglioli Türkiye**

Atatürk Organize Sanayi Bölgesi,  
10015 Sk. No: 17, Çigli - Izmir  
Tel. +90 (0) 232 328 22 77 (pbx)  
Fax +90 (0) 232 328 04 14  
www.bonfiglioli.com.tr  
info@bonfiglioli.com.tr

## **Bonfiglioli United Kingdom**

**Industrial Solutions**  
Unit 7, Colemeadow Road  
North Moons Moat - Redditch,  
Worcestershire B98 9PB  
Tel. (+44) 1527 65022 - Fax (+44) 1527 61995  
www.bonfiglioli.com  
uksales@bonfiglioli.com

**Mobile Solutions**  
3 - 7 Grosvenor Grange, Woolston  
Warrington - Cheshire WA1 4SF  
Tel. (+44) 1925 852667 - Fax (+44) 1925 852668  
www.bonfiglioli.co.uk  
mobilesales@bonfiglioli.co.uk

## **Bonfiglioli USA**

3541 Hargrave Drive Hebron, Kentucky 41048  
Tel. (+1) 859 334 3333 - Fax (+1) 859 334 8888  
www.bonfiglioliusa.com

## **Bonfiglioli Vietnam**

Lot C-9D-CN My Phuoc Industrial Park 3  
Ben Cat - Binh Duong Province  
Tel. (+84) 650 3577411 - Fax (+84) 650 3577422  
www.bonfiglioli.vn  
salesvn@bonfiglioli.com





Bonfiglioli has been designing and developing innovative and reliable power transmission and control solutions for industry, mobile machinery and renewable energy applications since 1956.